

PARAVAN®

PARAVAN WHEELCHAIR SERIES

User manual PR 35 S

 EN V1.4



Valid for the following model
Publisher and Copyright:
Date of issue:
Document number:

Paravan PR 35 S
PARAVAN GmbH
01/12/2021
PR35 S_V1.4 EN

Dear customer,

We would like to thank you for choosing our PARAVAN PR 35S standing wheelchair.

These operating instructions contain all the important information and instructions regarding your new PR 35S. We ask that you carefully read the following pages to ensure that your PR 35S will continue to work without problems for many years to come. Keep these operating instructions "to hand" for future reference. Our operating instructions contain answers to questions that relate to the equipment, operation and care of the PR 35S. However, if you still have questions or comments regarding the PR 35S, please do not hesitate to contact us.

Your PARAVAN Team

Contents

General

1.	Legal notice	15
1.1	Your manufacturer	15
1.1.1	Copyright	16
1.1.2	Technical status of documentation.....	16
2.	Regarding these operating instructions	17
2.1	Exclusion of liability	18
2.1.1	Guarantee	19
2.1.2	Technical modifications	20
2.2	Target group.....	22
2.3	Explanation of symbols.....	23
2.3.1	Structure of safety notes.....	24
3.	Safety notes	25
3.1	Generally applicable safety notes.....	25
3.1.1	Operation instructions.....	25
3.1.2	Information regarding use.....	29
3.1.3	Information regarding transport	30
4.	Performance description	31
4.1	Manufacturing standard.....	31
4.2	Correct use.....	32
4.2.1	Usability of the PR 35S.....	33
4.2.2	Clearance declaration for non-dangerous goods (storage battery)	34
4.3	Approvals, certifications.....	35
4.3.1	EU approval as a driver seat.....	35
4.3.2	German regulations on assistive technology (Hilfsmittelverordnung, H MV no.)	36
4.3.3	Definition of auxiliary equipment (incomplete excerpt)	36

4.3.4	Indication.....	37
4.3.5	Contraindications.....	37

Information

5.	Product-specific data	38
5.1	Trademark and type designation (type plate)	38
5.2	Location of the type designation (type plate)	39
5.3	Important information about your PR 35S.....	40
5.3.1	The type plate of your PR 35S	40
5.4	Accessories.....	41
5.4.1	Supplied accessories.....	41
5.4.2	Deliverable accessories.....	41
6.	Description/function of the PR 35S	42
6.1	The seat.....	42
6.2	Joystick control.....	43
6.3	Special control system	43
6.4	Tilt function (seat angle)	44
6.5	Road-safe in accordance with The Road Traffic Licensing Act (StVZO).....	45
6.5.1	§ 24 Special means of transportation.....	45
7.	Overview of the PR 35S.....	46
7.1	Parts and their locations	46
7.2	Parts and their installation position, chassis.....	47

Prepare

8.	Handover of the PR 35S	49
8.1	Receiving your new PR 35S	49

8.2	How the PR 35S is supplied to you	49
9.	Settings on the PR 35S, electronic	50
10.	Settings on the PR 35S, mechanical	51
10.1	Receiving your new PR 35S	51
10.2	The armrest pad.....	52
10.2.1	Set the angle of the armrest pad.	52
10.2.2	Set the horizontal position of the armrest pad	53
10.3	Armrest.....	54
10.4	Set the height of the armrest	55
10.5	Angle of the armrest	56
10.6	Set the projection of the armrest.....	57
10.7	Setting the mobility of the control panel	58
10.8	Footrest unit	59
10.8.1	Setting the lower leg length.....	59
10.8.2	Setting the tibial angle.....	60

Operate

11.	Driving with the PR 35S.....	61
11.1	Insurance, liability insurance.....	61
11.2	Function check before the trip	62
11.3	Controlling the PR 35S, directions of travel	63
11.4	Navigating bends, turning corners.....	64
11.5	Braking with the PR 35S.....	65
11.5.1	PR 35S braking system	65
11.6	PR 35S braking characteristics	66
11.7	Travelling on hills, up and downhill travel.....	67
11.8	The drive programs / movement levels.....	68

11.9	Manual driving, push mode.....	69
11.9.1	Operation of the brake lock release lever (emergency release)	69
11.10	Information regarding roads, types of ground	70
11.10.1	Fording ability, driving through water	70
11.10.2	Climbing / traversing ability	71
11.10.3	Load bearing capacity	71
11.10.4	Rough ground or terrain.....	71
11.10.5	Slippery ground, traction	71
12.	Parking and storing the PR 35S.....	72
13.	Loading and transporting the power wheelchair.....	73
13.1	Rules for loading wheelchairs.....	73
13.2	Securing and fastening the power wheelchair.....	74
13.3	Fasten the seatbelt in a moving vehicle	75
13.4	Securing the wheelchair with a 4 point strap restraint.....	76
13.5	Occupant restraint instruction	77
13.6	Dahl Docking Systems Assembly	79
13.6.1	Content of Dahl docking stations	81
13.6.2	Attaching the Dahl locking plate to the wheelchair	83
13.6.3	Attaching the Dahl locking plate to the wheelchair	85
13.6.4	Description of the Dahl Docking system functions	89
13.6.5	Securing the wheelchair in the docking station.....	90
13.6.6	Release from the docking station.....	92
13.6.7	Manual release in case of electric failure	93
14.	Controls	94
14.1	Control panel R-NET CJSM2	94
14.1.1	Overview of the control elements.....	94
14.1.2	Status display.....	95
14.1.3	Start, switch off.....	96

14.1.5	Switch direction indicator on and off	97
14.1.4	Switch light on and off.....	97
14.1.6	Switch hazard lights on and off	98
14.1.7	Driving functions overview	99
14.1.8	Select drive program, drive.....	100
14.1.9	Electrical seat adjustment.....	101
14.1.10	Set time/date	102
14.1.11	Show/hide clock, configure 12h/24h display.....	103
14.1.13	Adjust display brightness	104
14.1.12	Adjust display brightness, automatic (recommended)	104
14.1.14	Block the controls (with the wheelchair switched on)	105
14.1.15	Release the controls (with the wheelchair switched off)	105
14.2	Control panel R-NET CJSM-L	106
14.2.1	Overview of the control elements	106
14.2.2	Status display.....	107
14.2.3	Start and switch off	108
14.2.4	Switch light on and off.....	109
14.2.5	Switch direction indicator on and off	109
14.2.6	Switch hazard lights on and off	110
14.2.7	Driving functions overview	111
14.2.8	Select drive program, drive.....	112
14.2.9	Electrical seat adjustment.....	113
14.2.10	Set time/date	114
14.2.11	Show/hide clock, configure 12h/24h display.....	115
14.2.12	Adjust the display background and brightness	116
14.2.13	Adjust display brightness	116
14.2.14	Block the controls (with the wheelchair switched on)	117
14.2.15	Release the controls (with the wheelchair switched off)	117

Help

15.	Moving out of the PR 35S seat	118
15.1	Procedure when moving sideways out of the seat.....	119
16.	Maintenance and servicing.....	120
16.1	Service partner.....	120
16.2	Cleaning and care	121
17.	Disposal and environmental protection.....	122
17.1	Packaging material.....	123
17.2	Recommissioning.....	124
17.3	Information regarding transfer of the product.....	125
18.	Troubleshooting	126
18.1	Status indicator on the control panel	126

Technology

19.	Electrical system.....	128
19.1	Automatic fuses.....	128
19.2	Main fuse.....	129
19.2.1	Resetting a triggered main fuse.....	129
19.3	Overload protection	130
19.3.1	Reset the triggered overload protection:.....	130
19.4	Connection option for auxiliary units.....	131
19.5	The lighting installation	132
19.6	Maintenance-free storage batteries	133
19.7	Information regarding storage batteries	134
19.8	Charging the PR 35S	135

19.8.1	Procedure for charging the PR 35S.....	136
19.8.2	The charger	137
19.8.3	Installing the charger, installation location	137
20.	Technical equipment	138
20.1	Technical data and measurements	138
20.2	Spare parts	143
21.	Electromagnetic compatibility (EMC).....	145
21.1	Information regarding electromagnetic compatibility.....	145
21.2	Compliance level.....	146
22.	Annexes and technical documentation	149
22.1	Handling of sealed storage batteries	149
22.2	Customer service booklet	150
22.3	EC declaration of conformity	151
22.4	Log of instructions provided upon delivery.....	152

Fig. 1:	QR code	15
Fig. 2:	Direction of travel.....	17
Fig. 3:	Safety instruction.....	24
Fig. 4:	TÜV Logo.....	35
Fig. 5:	Type plate	38
Fig. 6:	Location of type plate.....	39
Fig. 7:	DAHL docking station.....	41
Fig. 8:	DAHL Vario Dock (height adjustabel).....	41
Fig. 9:	Illumination at the front	45
Fig. 10:	Illumination at the rear	45
Fig. 11:	Wheelchair overview.....	46
Fig. 12:	Parts, chassis rear	47
Fig. 13:	Parts, chassis front.....	48
Fig. 14:	Angle of armrest pad	52
Fig. 15:	Position of the armrest pad	53
Fig. 16:	Position check of the armrest.....	54
Fig. 17:	Height of armrest.....	55
Fig. 18:	Armrest angle.....	56
Fig. 19:	Armrest projection	57
Fig. 20:	Swivel mechanism.....	58
Fig. 21:	Lower leg angle.....	59
Fig. 22:	Tibial angle.....	60
Fig. 23:	Brake lock release lever (emergency release)	62
Fig. 24:	Joystick	63
Fig. 25:	Brake lock release lever (emergency release)	69
Fig. 26:	Attachment point at the front.....	74
Fig. 27:	Attachment point at the rear	74
Fig. 28:	Illustration of improper belt-restraint fit	75
Fig. 29:	Illustration of proper belt-restraint fit.....	75

Fig. 30:	Rear securement points	76
Fig. 31:	Front securement points	76
Fig. 32:	Positioning the occupant restraint with 4 point strap system	77
Fig. 33:	Positioning the occupant restraint for use with dahl docking system only	78
Fig. 34:	Dahl docking system	79
Fig. 35:	Content of Dahl Docking Station MK II standard set # 501750.....	81
Fig. 36:	Content of Dahl VarioDock™ standard set # 503600	82
Fig. 37:	Dahl Adaptationkit for Dahl Docking Station	83
Fig. 38:	Torx TX 27	83
Fig. 39:	Knurled screws Paravan.....	84
Fig. 40:	Rear and side covers Paravan.....	84
Fig. 41:	Main cable battery	85
Fig. 42:	Removing the batteries	85
Fig. 43:	Position of the Dahl system	86
Fig. 44:	Fastening of the Dahl system	86
Fig. 45:	System functions Dahl	89
Fig. 46:	Manual release step 1	93
Fig. 47:	Manual release step 2	93
Fig. 48:	Control panel R-NET CJSM2	94
Fig. 49:	Function keys	95
Fig. 50:	Status display.....	95
Fig. 51:	Speed control (tortoise) active	96
Fig. 52:	„On / off“ key	96
Fig. 53:	Light on and off	97
Fig. 54:	Turn signal right / left	97
Fig. 55:	Light symbol (colour).....	97
Fig. 56:	Hazard lights on / off	98
Fig. 57:	Symbols (colour).....	98
Fig. 58:	Driving functions.....	99

Fig. 59:	Charging status indicator (driving function blocked).....	99
Fig. 60:	Select drive program.....	100
Fig. 61:	Joystick travelling direction	100
Fig. 62:	Example: Display of seat functions	101
Fig. 63:	"Set time" function menu.....	102
Fig. 64:	Setting the time and date	102
Fig. 65:	Set clock to visible/invisible.....	103
Fig. 66:	Setting the display brightness.....	104
Fig. 67:	Autom. display brightness	104
Fig. 68:	Blocking the controls	105
Fig. 69:	Lock symbol	105
Fig. 70:	Control panel R-NET CJSM-L	106
Fig. 71:	Function keys	107
Fig. 72:	Status display.....	107
Fig. 73:	"On / off" key	108
Fig. 74:	Speed control (tortoise) active	108
Fig. 75:	Light on and off	109
Fig. 76:	Turn signal right / left	109
Fig. 77:	Light symbol (colour).....	109
Fig. 78:	Hazard lights on / off	110
Fig. 79:	Symbols (colour).....	110
Fig. 80:	Driving functions.....	111
Fig. 81:	Driving function blocked.....	111
Fig. 82:	Select drive program.....	112
Fig. 83:	Joystick travelling direction	112
Fig. 84:	Display of seat functions.....	113
Fig. 85:	"Set time" function menu.....	114
Fig. 86:	Setting the time and date	114
Fig. 87:	Set clock to visible/invisible.....	115

Fig. 88:	Setting the display brightness	116
Fig. 89:	Setting the display background	116
Fig. 90:	Blocking the controls	117
Fig. 91:	Controls blocked – block symbol	117
Fig. 92:	Move from the seat, footrests.....	119
Fig. 93:	Move from the seat, armrest.....	119
Fig. 94:	Recycling	123
Fig. 95:	Main fuse, active.....	129
Fig. 96:	Main fuse.....	129
Fig. 97:	Illumination at the front	132
Fig. 98:	Illumination at the rear	132
Fig. 99:	Plug in the charging cable.....	136
Fig. 100:	Set up charger	137
Fig. 101:	EC declaration of conformity	151

1. Legal notice

1.1 Your manufacturer



Fig. 1: QR code

PARAVAN GmbH
Registered office / headquarters / production



Paravanstraße 5-10, D-72539 Pfronstetten-Aichelau

- > Tel.: +49 73 88 / 99 95-91
- > Fax: +49 73 88 / 99 95-999
- > Email: info@paravan.de
- > Internet: www.paravan.com
- > Managing Director: Mr. Roland Arnold



Many mobile telephones and PDAs have built-in cameras and software which allows the interpretation of QR codes, and with these you can directly transfer our contact information into the address book of your mobile phone or PDA.

1.1.1 Copyright

This documentation and all of its parts are protected by copyright. All rights arising from this copyright, especially those relating to the translation, reprint, presentation, use of illustrations and tables, radio broadcasting, microfilming or reproduction of information in other ways, and the storage of such information in data processing systems, also with regard to the use of specific extracts, remain reserved. The reproduction of this work or a part of this work, even in individual cases, is only permitted within the limits of the statutory provisions of the current version of the Copyright Act (Urheberrechtsgesetz) of the Federal Republic of Germany of 9 September 1965. Such reproduction is generally subject to a fee. Contraventions are subject to the penal provisions of the Copyright Act.

➤ Copyright © PARAVAN GmbH 2021. All rights reserved!

1.1.2 Technical status of documentation

All details on technical data / specifications, illustrations and information in these operating instructions correspond to the information available at the editorial deadline in 2021.

The operating instructions for the PR 35S have been produced in the German language and can be translated into other languages; however in the case of any differences, the German version is legally binding.

2. Regarding these operating instructions



Fig. 2: Direction of travel

These operating instructions do not constitute a maintenance and repair manual and therefore are not suitable to use for the private carrying out of maintenance and repair work, or to provide instruction on this. You will receive information on the design and the operation of the product throughout its entire life cycle – from transport (delivery) to decommissioning (shutdown) of the PR 35S. The most important product features are listed and described below. All the specified product features can be combined with one another in different variants and functions, and can potentially differ from the series-production standard.



NOTE

These operating instructions are an essential part of the power wheelchair product and must always be kept near the PR 35S so that you can quickly access all important information.



All information on sides and directions in this documentation is always specified from the point of view of the operator and in the direction of travel!

2.1 **Exclusion of liability**

The operation of the PR 35S without faults or malfunctions can only be guaranteed if the information gained from these operating instructions is applied. PARAVAN GmbH assumes no liability or guarantee regarding damage or malfunctions that occur during operation due to the non-observance of these operating instructions or due to modifications made to the PR 35S.

In order to guarantee the fault-free operation of your PR 35S, please observe the maintenance instructions and maintenance intervals.



See chapter “17 Maintenance and servicing”

2.1.1 Guarantee

Guarantee services are based entirely on the respective PARAVAN guarantee provisions.

Excluded from guarantee claims is damage which has occurred due to:

- > Wear
- > Improper operation or use, e.g. overloading
- > Incorrect/infrequent maintenance
- > Incorrect/infrequent care



See your personal "guarantee card".

2.1.2 Technical modifications

All modifications to safety equipment, and technical modifications to the PR 35S in general, even if only minor, are strictly prohibited! All modifications must be authorised or carried out by PARAVAN GmbH.

PARAVAN GmbH reserves the right to undertake technical modifications and improvements to the product in the interest of our customers and progressive development.



NOTE

Claims relating to the guarantee and warranty shall expire in the event that any modification is made to the PR 35S that was not authorised by PARAVAN GmbH. Furthermore, dangerous malfunctions cannot be ruled out!

 WARNING	
>	Danger of injury for persons operating a PR 35S which does not correspond to the original or delivered condition.
>	Material damage to the PR 35S through the use of unapproved parts or incorrectly installed parts.
>	Do not make any technical modifications to the power wheelchair.
>	Only operate the PR 35S in its original or delivered condition.
>	Use only original and approved replacement parts.
>	Check the operating condition of the PR 35S before each trip.

2.2 Target group

The operator must acquire or gain a level of knowledge relating to the following points before operating the PR 35S:

- > Knowledge of the content of the operating instructions in order to safely operate and also be able to move the PR 35S.
- > Knowledge of the safety and operating provisions listed herein in order to recognise potential dangers or dangerous situations and avert these for the user and his/her surroundings.



NOTE:

In order to ensure their own personal safety, only trained or instructed persons may operate a power wheelchair. As a user, please ensure you receive sufficient training when the product is supplied. If necessary, please contact us.



See section "24.4 Log of instructions upon supply"

2.3 Explanation of symbols

When reading the operating instructions you will encounter the following symbols and warning symbols.



The "Caution Danger!" logo

highlights hazards. The protective measures specified in the respective text must be followed in all cases. This symbol is always used in combination with the respective signal word, which indicates the level of danger:

- > **Danger!** - Immediate danger to life and limb (irreversible).
- > **Warning** - potential danger to life and limb (irreversible).
- > **Caution** - potential danger to life and limb (reversible).
- > **Caution** - potential damage to the vehicle.



Additional information for the user – e.g. in order to simplify the operation of the PR 35S and/or avoid damage to the PR 35S.



This symbol refers the user to further sections or further documentation – e.g. also to annexes of these operating instructions.

2.3.1 Structure of safety notes

You can obtain the following information from the safety notes:

- Warning or danger symbol ①.
- Type and source of the danger ②.
- Signal word ③.
- Consequences of hazard occurring ④.
- Protective measures ⑤.

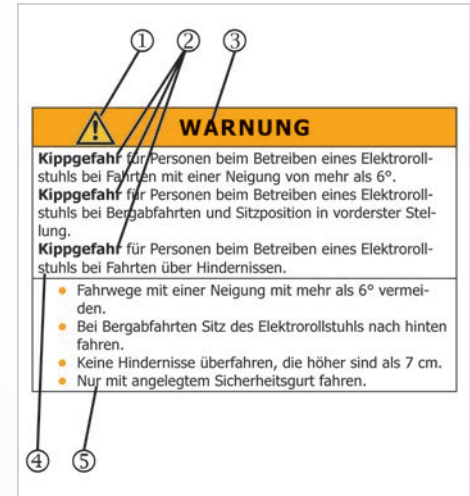



Fig. 3: Safety instruction

3. Safety notes

3.1 Generally applicable safety notes

3.1.1 Operation instructions

For your protection and for the protection of people in your vicinity and of the environment, the following safety instructions must be observed and followed at all times.

 DANGER!	
>	Danger of crushing from touching moving parts, e.g.
>	from the rotational movement of the drive wheels or the
>	lifting motion of the functional unit.
>	Danger of falling due to unintentional movement of the PR 35S due to an inactive braking mechanism.
>	Danger of falling from abrupt braking of the PR 35S if the vehicle is without power.
>	Do not touch moving parts.
>	Assistants must not touch parts in the danger zones while operating the power wheelchair.
>	Brake lock release lever must be in the "LOCK" position.
>	Never switch the power of the PR 35S off or shut it down while travelling.



WARNING

Danger of tipping for persons operating a PR 35S when travelling at an incline of more than 10°.

Danger of tipping for persons operating a PR 35S when travelling downhill and if the seat is in the foremost position.

Danger of tipping for persons operating a PR 35S when travelling over obstacles.

- > Avoid routes with inclines greater than 10°.
- > Tilt the seat of the PR 35S back when travelling downhill.
- > Do not cross any obstacles which are higher than 60-70 mm.
- > Only drive with your seatbelt fastened
- > Do not drive in a horizontal (lying) position.
- > Only drive in the lowest seat position.
- > Only use the lifting, recline and tilting function on level surfaces.



WARNING

Danger of injury for persons operating a PR 35S which does not correspond to the original or delivered condition.

Material damage to the PR 35S through the use of unapproved parts or incorrectly installed parts.

- > Do not make any technical modifications to the power wheelchair.
- > Only operate the PR 35S in its original or delivered condition.
- > Use only original and approved replacement parts.
- > Check the operating condition of the PR 35S before each trip.



WARNING

Danger of injury for persons while travelling with a PR 35S on rough ground.

Danger of falling and tipping for persons while operating the PR 35S on surfaces with diminished load bearing capacity.

Material damage to the PR 35S from mechanical and physical influences while travelling on rough terrain.

- > Avoid travelling on flat, slippery or greasy surfaces (e.g. ice, snow, wet grass, foliage, etc.).
- > Avoid travelling through water with a depth of 50mm or more.
- > Observe the gross load weight of the vehicle.
- > Observe the load bearing capacity (e.g. in the case of bridges or crosswalks) or condition of the ground.
- > Only drive with your seatbelt fastened.

3.1.2 Information regarding use

 CAUTION	
Material damage to the PR 35S from overloading the vehicle.	
Material damage to the PR 35S from the effects of high temperatures above 41°C.	
Material damage to the PR 35S from overcharging of the batteries when travelling downhill.	
<ul style="list-style-type: none">> Only use the PR 35S for its intended purpose.> Overloading the PR 35S (e.g. with a second person or other loads) is not permitted.> Protect the PR 35S from strong solar radiation and other sources of heat.> Switch on the electricity consumers (e.g. the lights) when travelling downhill.> When using the reclining function, always remove the warning triangle.	

3.1.3 Notes on transport



CAUTION

Material damage to the electric wheelchair through slipping from ramps or lift while being loaded.

Material damage to the electric wheelchair through being secured and transported improperly in and electric wheelchair transporter.

- > Secure ramp from slippage.
- > Both the ramp and the electric wheelchair transporter must be positioned on even and firm surfaces.
- > The ramp or lift must be clean and dry.
- > The ramp must be wider than the electric wheelchair and should be clearly visible to allow corrective steering.
- > Mount the ramp and lift in a single movement in order to prevent the electric wheelchair rolling backwards.
- > Secure the electric wheelchair in the transporter according to the usual legal regulations.
- > Use only suitable and authorised securing equipment.
- > Switch the electric wheelchair off during transport.

National regulations may prevent you from taking it on buses, trains and air transport.



Ask your transport company about possible restrictions.



Before travelling by air, clarify the specific transport conditions with your airline as well as the legal regulations applicable in your country of origin or at your destination with regard to air transport.

4. **Performance description**

4.1 **Manufacturing standard**

The PARAVAN PR 35S is a multifunctional power wheelchair that is ideal for indoor and outdoor use due to its compactness and manoeuvrability.

The PR 35S is designed and tested to ensure the highest possible degree of safety for the operator and his/her surroundings. Our products are checked for faults after their manufacture. If a fault or malfunction nevertheless arises with your PR 35S, we ask that you contact your dealer or PARAVAN GmbH directly so that the issue can be dealt with.

PARAVAN power wheelchairs are manufactured and tested in accordance with:

- DIN EN 12184 Electrically powered wheelchairs, scooters and their chargers.

and are classified as Category B in this standard.

4.2 Correct use

The PARAVAN PR 35S is designed to transport a person indoors and outdoors. The control panel, including the joystick and optional controls for special operation, serves as the interface in terms of user operation and the liability of the manufacturer of the PR 35S.

**NOTE**

The PR 35S is only intended for the uses listed in the section “Usability of the vehicle”.



See section “3 Safety notes”



See section “4.2.1 Usability of the PR 35S”

4.2.1 Usability of the PR 35S

- unproblematic

- Transport of a person with a maximum body weight of 140kg.
- Use as driver's or co-driver's seat, depending on the equipment variant.
- Use within the German road traffic regulations ("StVO"), assuming complete and intact lighting.



See section "12 Driving with the PR 35S"

- problematic or prohibited

- Use as a means of tractive transport of loads or of several people.
- Use of the PR 35S in extreme climatic conditions (heat/cold/moisture).



See section "2.1 Exclusion of liability"



See section "3 Safety notes"

4.2.2 Clearance declaration for non-dangerous goods (storage battery)

PARAVAN GmbH uses storage batteries which are classified as "non-dangerous goods", as long as these storage batteries are not mechanically damaged in any way.

The maintenance-free non-woven lattice storage batteries and the maintenance-free lead gel storage batteries are leak-proof, and in accordance with

- > IATA, regulation A 67
- > ADR, regulation 238 B
- > IMDG, regulation 238.2 and

UN 2800 Special Provisions are considered **not dangerous goods** and suitable for transport.



See "Clearance certificate for non-dangerous goods"



You will receive the respective appropriate clearance certificate for your storage batteries when you receive your PR 35S.

4.3 Approvals, certifications

4.3.1 EU approval as a driver seat

The anchoring of the safety belt has been certified and approved in accordance with 76/115/EEC as has the seat in relation to its anchoring in accordance with 74/408/EWG with the Paravan docking system.

 DANGER!
Potential risk of injury or serious injury or death
<p>In conjunction with the Dahl Docking system the wheelchair has been successfully crash-tested according to ISO 7176-19:2008 - Wheeled mobility devices for use as seats in motor vehicles. The test was carried out with vehicle anchored safety belt system only. The integrated 3- or 4-point seat belt should not be used or relied on for occupant restraint in a moving vehicle. Use a vehicle installed and approved 3 point belt instead.</p>



Fig. 4: TÜV Logo

> Technical Reports Nos. 08-00719-CP-GBM and 08-00723-CP-GBM.



See Section "23 Annexes and technical documentation"

4.3.2 German regulations on assistive technology (Hilfsmittelverordnung, HMV no.)

The PR 35S standing wheelchairs are approved in accordance with assistive technology guidelines:

- Kassenarztrecht in Nordwürttemberg – Richtlinien und Normen und Verordnungen und Leistungen (Panel doctors law in Northern Württemberg - guidelines and standards and regulations and services), page B 2 - 1 ff

As auxiliary equipment permitted under the German regulations on assistive technology, number:

- HMV no. 18.99.03.2038

4.3.3 Definition of auxiliary equipment (incomplete excerpt)

Auxiliary devices are physical medical services i.e. things which succeed in making medical treatment safe by their compensatory, supportive or relieving effect, or which allow physical hindrances to be overcome. They include prostheses, orthopaedic and other auxiliary equipment, visual aids, physical tools or technical products...

4.3.4 Indication

The inability to walk or severely limited ability to walk within the context of the basic need to move in your own home.

The provision of wheelchairs with a standing feature is advisable if regular (several times per day) standing training must be carried out as a therapeutic action, and other standing aids, e.g. underarm crutches, axillary crutches, walking frames, cannot be used.

These wheelchairs are only used if manually operated standing devices cannot be operated due to the wheelchair user's low level of residual strength.

4.3.5 Contraindications

The provision of power wheelchairs is unsuitable for persons with:

- > Severe balance disorders
- > Limited and inadequate vision
- > Severely limited cognitive abilities
- > Loss of both arms, or the inability to sit

5. Product-specific data

5.1 Trademark and type designation (type plate)

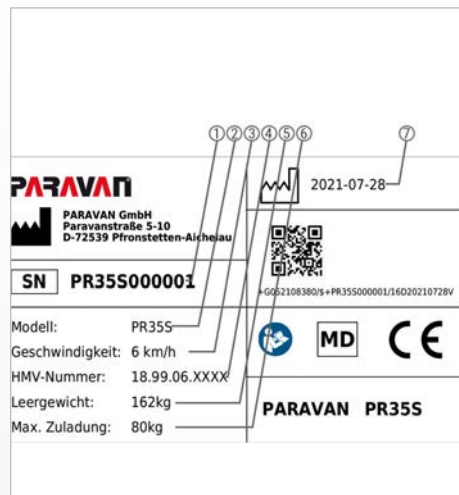

This information can be found on the type plate. It is very important to provide this in any correspondence with PARAVAN GmbH so that you receive relevant professional advice.

- > Series number, chassis no. ①
- > Model name ②
- > Max. speed ③
- > HMV number ④
- > PR 35S unladen weight ⑤
- > Max. payload (body weight) ⑥
- > Production date ⑦

Fig. 5: Type plate



See section “5.3.1 Type plate of your PR 35S”

5.2 Location of the type designation (type plate)

The type designation (type plate) is affixed to the PR 35S in a 1-fold design. The type designation (type plate) has dimensions of approx. 70 mm x 40 mm.

- > The type designation (type plate) is situated on the rear right of the battery box ① of the PR 35S.



Fig. 6: Location of type plate

5.3 **Important information about your PR 35 S**

Please make sure this information is recorded when you receive the PR 35S, or if necessary enter the information yourself, so that you always have it to hand.

- > Day of delivery/supply
- > Supply by (dealer or branch)

5.3.1 The type plate of your PR 35S

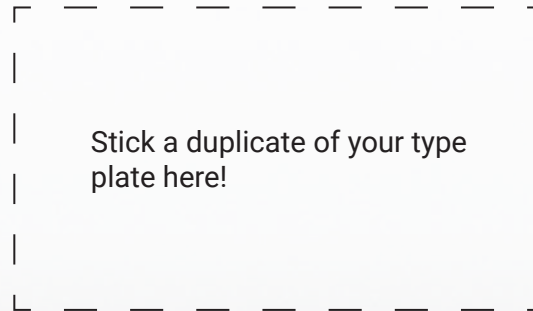

5.4 Accessories

5.4.1 Supplied accessories

- Charger with charging cable.
- Operating instructions.
- Socket wrench with T-handle, SW 13.
- Allen key, size 5.

5.4.2 Deliverable accessories

- DAHL docking station for quick and easy fastening of the PR 35S in a vehicle.



Fig. 7: DAHL docking station



Fig. 8: DAHL Vario Dock (height adjustable)

6. **Description/function of the PR 35 S**

6.1 **The seat**

The PR 35S seat is an in-house development from PARAVAN GmbH that is precisely tailored to the needs of customers. The PR 35S features:

- Special shock absorbers in the seat to provide relief to the thigh muscles.
- 6-axes with 12-fold individual adjustment of the armrest in order to be able to set an optimum and fatigue-free position for the arms.
- MeshTex textile cover made from breathable nanofabric to reduce the risk of decubitus.

General

Information

Prepare

Operate

Help

Technology

6.2 Joystick control

All the functions of the PR 35S can be selected or accessed via the joystick, the control panel and the integrated control system. Such functions include:

- > steering,
- > braking behaviour,
- > speed, control of the two drive motors,
- > secondary functions, depending on which control system or equipment is used.

6.3 Special control system

A multitude of special controls, such as

- > chin control,
- > environmental control,
- > etc.

can be implemented in the PR 35S.



If you have requests or suggestions for us regarding this, please do not hesitate to contact us. Thank you.

6.4 **Tilt function (seat angle)**

The PR 35S is equipped with a tilt function. The tilting process can be interrupted and fixed in any direction of movement and at any position.

The seat tilt (angle) can be set as follows at the touch of a button:

> forwards, thus also serving as a standing aid

or

> backwards – for relaxing, preventing pressure sores, easing back pain and ensuring better weight distribution.



See section “11 The seat, operation”

6.5 Road-safe in accordance with The Road Traffic Licensing Act (StVZO)

The PR 35S is a road-approved vehicle that includes the following features as standard equipment:

- LED headlights for optimum illumination ①.
- LED direction indicator ②.
- LED rear lights for the best possible visibility ③.
- Identification by yellow reflectors on the side in the middle of the wheel.



Fig. 9: Illumination at the front

6.5.1 § 24 Special means of transportation



The Road Traffic Licensing Act (StVZO) makes reference to wheelchairs. In it, it is stated that:

- (1) Push and gripping wheelchairs, sledges, prams, scooters, children's bikes and similar means of transportation are not vehicles as defined in this Act.
- (2) Wheelchairs or other wheelchairs as defined in section 1 may be driven in places where there is pedestrian traffic, however only at walking speed.



Fig. 10: Illumination at the rear

7. Overview of the PR 35 S

7.1 Parts and their locations

General

Information

Prepare

Operate

Help

Technology



Fig. 11: Wheelchair overview

The following terms for parts or individual parts are used in the operating instructions. Their location on the PR 35S is shown in the photo.

- > Control panel with joystick ①
- > Armrest axle adjustable ②
- > Back rest (electric) ③
- > Headrest ④
- > Footplate/footrests ⑤
- > Brake lock release lever, emergency release ⑥
- > Drive wheel, standard version puncture-resistant ⑦
- > Battery box ⑧
- > Casing ⑨
- > Rear wheel, standard version puncture-resistant ⑩

7.2 Parts and their installation position, chassis

The following terms for parts or individual parts are used in the operating instructions. The installation position on the chassis of the PR 35S is shown in the photo.

- Seat plate ①
- Seat guides ②
- Rear wheel ③
- Rigging eye, rear ④
- Actuator module ⑤
- Battery box ⑥
- Storage battery ⑦

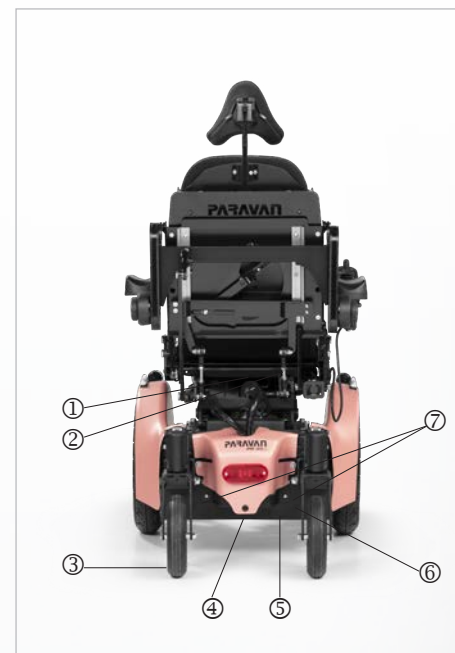
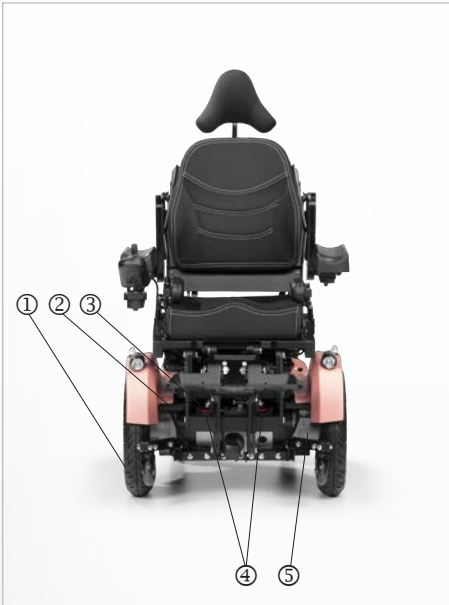

Fig. 12: Parts, chassis rear



- Drive wheel ①
- Rigging eye ②
- Control units ③
- Brake lock release lever, emergency release ④
- Drive motor ⑤

Fig. 13: Parts, chassis front

8. **Handover of the PR 35 S**

8.1 **Receiving your new PR 35 S**

Check your PR 35S for completeness and compare the items received in the delivery with your order documents. If anything is unclear, contact PARAVAN GmbH immediately!

Check (visually inspect) that the PR 35S is in proper condition. Report damage which can be attributed to delivery or transport immediately and in writing to your

> dealer, forwarding agent or medical supply store

and

> PARAVAN GmbH.

8.2 **How the PR 35 S is supplied to you**

The PR 35S is supplied to you in the following ready to drive and ready to operate condition:

- > Fully assembled and with equipment corresponding to your specifications upon ordering.
- > All attachments and control elements are preset to your body measurements in accordance with the order.
- > Precharged storage batteries.

9. Settings on the PR 35S, electronic

General

Information

Prepare

Operate

Help

Technology

The setting and configuration of the PARAVAN control unit is very complex and, for your own safety, can only be undertaken by your service technician.

All parameters of the PARAVAN control unit can be subsequently set to your requirements and desires. These include:

- > All driving features such as e.g. moving off and braking.
- > Steering behaviour.



If an adjustment of the control parameters is necessary or desired, please contact your dealer or PARAVAN GmbH.

10. Settings on the PR 35S, mechanical

10.1 Receiving your new PR 35S

All mechanical parts or equipment and control elements are set to your body dimensions. If adjustment is still needed however, this can be undertaken at any time. Your PARAVAN PR 35S is designed in such a way that it can be adjusted to your body dimensions in all respects.



For your own safety, only allow your service technician to carry out all mechanical settings or modifications to the equipment. The customer should not change these settings himself!



See section "24.4 Log of instructions upon supply"

10.2 Combination with non-manufacturer products



Any combination with components not supplied by us generally constitutes a modification of your power wheelchair. Ask us whether there is a valid combination approval from us.

10.3 The armrest pad



The angle of the armrest pad can be tilted. It can also be adjusted horizontally forwards or backwards, allowing it to be adapted for any purpose and to every body size.



Fig. 14: Angle of armrest pad

10.3.1 Set the angle of the armrest pad.

These instructions apply to both the right and left sides.

- Loosen hexagonal cap nut ①.
- Swing the armrest pad ② into the desired position.
- Tighten hexagonal cap nut ① , approx. 8 Nm.

10.3.2 Set the horizontal position of the armrest pad

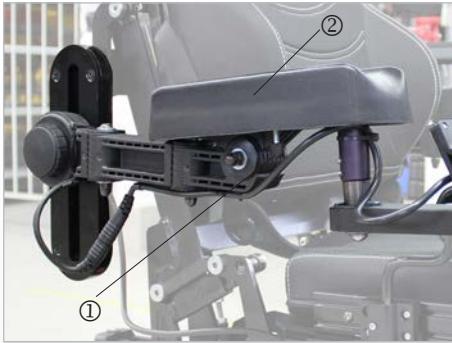

Fig. 15: Position of the armrest pad

These instructions apply to both the right and left sides.

Proceed as follows to check and set the position of the armrest pad:

- > Loosen the ① wing bolt.
- > Push the armrest pad ② forwards or backwards to the desired position.
- > Tighten the wing bolt ① hand-tight.

10.4 Armrest

The armrest is multi-horizontal in all directions (projection) and can be vertically adjusted or adjusted at an angle, and thus can be adapted to every body measurement.



Changing the position of the armrest potentially involves using another setting!

Proceed as follows to check and set the position of the armrest:

- Height ① of the armrest.
- Angle ② of the armrest.
- Projection ③ of the armrest.
- If required, correction of the armrest pad.



Fig. 16: Position check of the armrest

10.5 Set the height of the armrest



Fig. 17: Height of armrest

These instructions apply to both the right and left sides.

Turning the hand-operated wheel to the left releases the armrest, thereby enabling its height to be adjusted.

When the desired height is reached, turn the hand-operated wheel to the right and pull it tight.

> Armrest is locked or fixed.

10.6 *Angle of the armrest*



Fig. 18: Armrest angle

The armrest is pivoted on the attachment point. This allows the complete armrest to be swung upwards for comfortable sitting and standing or moving from the wheelchair's seat.

10.7 Set the projection of the armrest

This work instruction applies to the right and left sides; it is possible that the rotational direction of the screw connection is reversed!

Proceed as follows to check and set the projection of the armrest:

- Loosen hexagonal cap nut ①.
- Loosen hexagonal cap nut ③.
- Move the armrest ② into the desired position.
- Hexagonal cap nut ① and ③ tighten approx. 8 Nm.



Fig. 19: Armrest projection

10.8 *Setting the mobility of the control panel*



Fig. 20: Swivel mechanism

The horizontal swivel mechanism of the control panel can be set in relation to the degree of hardness (response behaviour or the mobility of the joints).

10.9 Footrest unit

The footrest unit's angle relative to the seat can be adjusted using the electrical angle compensation function. The angle of the footplates can only be altered manually using a set screw.

10.9.1 Setting the lower leg length

The lower leg support or lower leg length is set to your body dimensions.

- > Manually adjustable



Fig. 21: Lower leg angle

10.9.2 Setting the tibial angle



Fig. 22: Tibial angle

The support of the lower leg or the tibial angle (between upper and lower leg) can be electrically modified via the PARAVAN control unit in the angle adjustment setting, depending on the equipment version.

- > Select menu in the control unit.
- > Select the settings.



See section "15 Control"

11. Driving with the PR 35 S

11.1 Insurance, liability insurance

We recommend that you speak with your insurance advisor before starting to use the PR 35S so that its use is included in your insurance – in particular in your liability insurance.



Please note that within the context of applicable legal provisions, a legal requirement may exist to insure the PR 35S during use in road traffic.



WARNING

Danger of injury for persons operating a PR 35S which does not correspond to the original or delivered condition.

Material damage to the PR 35S through the use of unapproved parts or incorrectly installed parts.

- > Do not make any technical modifications to the power wheelchair.
- > Only operate the PR 35S in its original or delivered condition.
- > Use only original and approved replacement parts.
- > Check the operating condition of the PR 35S before each trip.

11.2 **Function check before the trip**

Before commencing each trip, the following points must be checked for your own safety:



It might be necessary to draw on the expertise of a second person for the check.

- > Function check of the brakes.



The brake lock release lever ① must be set to **"LOCK"**, i.e. point upwards.

- > Charging status of the storage batteries.
- > Function check of the lighting installation.



See section "12.9.1 Operation of the brake lock release lever (emergency release)"



See section "20 Electrical Equipment"



Fig. 23: Brake lock release lever (emergency release)

11.3 Controlling the PR 35S, directions of travel



The PR 35S is controlled via the joystick on the control panel.

The following basic control options are available if you put the joystick into the positions below:

- > Joystick forwards & The PR 35S travels forwards.
- > Joystick left or right & The PR 35S changes the direction of travel in accordance with the position selected.
- > Joystick backward & The PR 35S travels backwards.
- > Joystick in the neutral position (middle) & The brakes are active, the wheelchair does not travel.



In order to avoid unwanted movement of the PR 35S, do not perform any sudden movements (driving commands) on the joystick!



Firstly, practise controlling the wheelchair on safe and accessible terrain.



When the backrest and reclining function is activated, the Scoot Control collides with the backrest and the headrest holder. Therefore, please fold down the Scoot Control before operating this function!



Fig. 24: Joystick

11.4 Navigating bends, turning corners



The PARAVAN PR 35S is equipped with front-wheel drive. This means that the rear swings out during steering motions, i.e. turning corners.

This is how you navigate a bend:

- > Push the joystick into the required travelling position (forwards or backwards).

And at the same time,

- > push the joystick into the required travelling direction (left or right).

Example:

- > Push the joystick into the position, from the point of view of the operator, of right upwards (2:00 pm position) & The PR 35S curves to the right.



See section "3 Safety notes"

11.5 **Braking with the PR 35S**

11.5.1 PR 35S braking system

Two independently working braking systems (safety systems) are used in the PARAVAN PR 35S in order to guarantee the greatest possible level of safety. The PR 35S has a parking and service brake which complies with the Road Traffic Licensing Regulation (StVZO). The functions of the individual safety systems are as follows:

- > Safety during the trip: By releasing the joystick (the joystick always returns to its neutral position in the middle) in driving mode, the motor brake automatically switches itself on and brakes the PR 35S.
- > Safety in the case of a power cut or interruption: If there is an interruption to the power supply, e.g. due to a discharged storage battery, the safety magnet brake locks and the PR 35S comes to a standstill. If this is the case, it can only be mechanically unlocked and manually moved.



See section "12.9.1 Operation of the brake lock release lever (emergency release)"

11.6 PR 35S braking characteristics

The braking distance, i.e. the distance from initiating the braking process until the PR 35S comes to a standstill, is heavily dependent on factors such as:

- > Ground or condition of the road.
- > Total weight (vehicle and driver) of the PR 35S.



When braking from full speed at approx. 6km/h, your PR 35S has a braking distance of approx. 1 metre! During the braking process from high speeds, especially in the case of downhill travel, the power wheelchair can lurch from side to side or swerve. For this reason avoid sharp braking!

11.7 Travelling on hills, up and downhill travel

You must observe the following rules for your own safety when travelling up and downhill:

- > Put the longitudinal seat adjustment mechanism into the furthest back position in order to avoid slipping.
- > Only travel with your seatbelt fastened.
- > Avoid sharp braking during downhill travel so that the PR 35S does not lurch from side to side or swerve.
- > When travelling up and downhill select a low movement level or speed so that you don't lose control over the PR 35S at any time.
- > When travelling up and downhill from an incline of more than 7°, the stability of the PR 35S cannot be guaranteed, or there can be a danger of the PR 35S tipping.
- > The power generated during downhill travel is diverted into the battery. If the battery is fully charged upon commencing the trip, the safety system switches to emergency stop in order to avoid damage due to the overloading of the electronics. If this is the case, switch an electricity consumer (light) on in order to run down the battery, and then continue your trip.



The brake lock release lever must be set to "**LOCK**" when travelling up or downhill. The motor brake is only effective when set to "**LOCK**". The result of this would be travelling downhill without braking!



See section "12.9.1 Operation of the brake lock release lever (emergency release)"

11.8 The drive programs / movement levels

The PARAVAN PR 35S has five different drive programs, or movement levels. You can select the desired movement level or final speed of the PR 35S on the control panel.

The maximum final speed in the respective movement level is reached by moving the joystick as far as it will go.

The functions of the individual movement levels are as follows:

- > **Movement level 1:** Highest degree of control over the PR 35S; 20% of the final speed, driving indoors.
- > **Movement level 2:** 40% of the final speed.
- > **Movement level 3:** 60% of the final speed.
- > **Movement level 4:** 80% of the final speed.
- > **Movement level 5:** Only for practised drivers/operators; max. final speed.



See section "15 Control"

11.9 *Manual driving, push mode*

11.9.1 Operation of the brake lock release lever (emergency release)

- If you want to push the PR 35S, you must set both brake lock release levers ① on the left and right drive side to **"UNLOCK"** (downwards).



Do not set to **"UNLOCK"** on a gradient! In this position, the drive motor is unable to brake!

Positions of the brake lock release lever ①

LOCK

- Lever position upwards = driving; braking system is active!

UNLOCK

- Lever position downwards = pushing; braking system is deactivated!

CAUTION: During push mode the control unit must be switched off!



Fig. 25: Brake lock release lever (emergency release)

11.10 Information regarding roads, types of ground

General

Information

Prepare

Operate

Help

Technology



WARNING

Danger of tipping for persons operating a PR 35S when travelling at an incline of more than 10°.

Danger of tipping for persons operating a PR 35S when travelling downhill and if the seat is in the foremost position.

Danger of tipping for persons operating a PR 35S when travelling over obstacles.

- > Avoid routes with inclines greater than 10°.
- > Move the seat of the PR 35S back when travelling downhill.
- > Do not cross any obstacles that are higher than 60-70mm.
- > Only travel with your seatbelt fastened.

11.10.1 Fording ability, driving through water

- > When driving through water, damage to the electronic parts (motors, control units etc.) as well as to the storage batteries due to the ingress of water can occur.

11.10.2 Climbing / traversing ability

- > While travelling over obstacles that are higher than approx. 60-70 mm, you could touch the ground and get stuck or tip over with your PR 35S with the battery box.

11.10.3 Load bearing capacity

- Do not travel across grounds on which there is a danger that you could fall and therefore could become stuck or tip over. Keep the total weight of the vehicle in mind.



See section "22.1 Technical data and dimensions"

11.10.4 Rough ground or terrain

- When travelling on rough ground or terrain, there is a danger that you could get stuck or tip over with your PR 35S.
- On difficult terrain or over kerbs, only drive with the seat completely lowered! (because of the impact on the engine)

11.10.5 Slippery ground, traction

- When travelling over slippery ground (e.g. uncoated ramps, wet grass, snow, ice, etc.) your PR 35S can lose traction. This means that the drive power or the braking power is not transferred.



The PR 35S has a parking and service brake which complies with the Road Traffic Licensing Regulation (StVZO).

12. ***Parking and storing the PR 35S***

In order to avoid damage to the PR 35S, you must observe the following rules if you park the PR 35S (e.g. overnight) or do not use it for an extended time period:

- Create a connection to the charging device.
- Choose a dry parking space.
- Do not expose the PR 35S to high or to too low temperatures.
- Cover the PR 35S with a suitable cover.

13. Loading and transporting the power wheelchair



The power wheelchair must always be shut down and correctly secured or fastened in the transport vehicle. When loading the power wheelchair, you can use loading aids such as ramps, lifts and hoists with sufficient load-bearing capacity.

13.1 Rules for loading wheelchairs

The following rules must be observed for and during loading:

- > The maximum support height specified on the ramp must be greater than the height from the ground to the support edge to be cleared (e.g. in the case of a car, the car boot area).
- > Check the loading capacity of the ramp(s), of the lift or the hoist.
- > Due to safety reasons, the power wheelchair may only be loaded into cars or on split ramps when unoccupied (without baggage or a person).
- > Loading may only be carried out by a person who can safely operate and control your power wheelchair.
- > A power wheelchair which is unfit to drive may only be loaded by your authorised specialist workshop. This workshop is the only entity aware of the possible danger situations and how to counter them.

13.2 Securing and fastening the power wheelchair

The power wheelchair must be connected or tied to the transport vehicle with tightening straps, hooks or loops in order to prevent slipping. The power wheelchair must be fastened in accordance with the guideline

- DIN 75078 (parts 1 and 2) "Vehicles for the transportation of persons with reduced mobility"

The power wheelchair has the following attachment points:

- At the front, two rigging eyes ①
- At the rear, one rigging eye ②



If your vehicle is equipped with a DAHL docking station, further fastening is not necessary.



See section "5.4.2. Deliverable accessories"



Fig. 26: Attachment point at the front



Fig. 27: Attachment point at the rear

13.3 Fasten the seatbelt in a moving vehicle

 **DANGER**

Belt must not be held away from the body by wheelchair components such as armrests or wheels.

 **DANGER**

Belt restraints should make full contact with the shoulder, chest and pelvic. Belts should be positioned low on the pelvis near the thigh-abdominal junction.

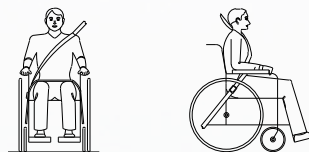

Fig. 28: Illustration of improper belt-restraint fit

Fig. 29: Illustration of proper belt-restraint fit

13.4 Occupant restraint instruction

- Use a vehicle anchored occupant restraint system to secure the occupant.
- Both pelvic and upper torso restraint belts must be used to restrain the occupant to reduce the possibility of head and should not be held away from the body by wheelchair components such as armrest or wheels.
- Restraints should be mounted to appropriate vehicle pillar and should not be held away from the body by wheelchair components such as armrest or wheels.



WARNING

Positioning the occupant restraint with 4 point strap system

- Pelvic restraint belt must be worn low across the front of the pelvis so that the angle of the pelvic belt is within the preferred zone of 30° - 75° to the horizontal.

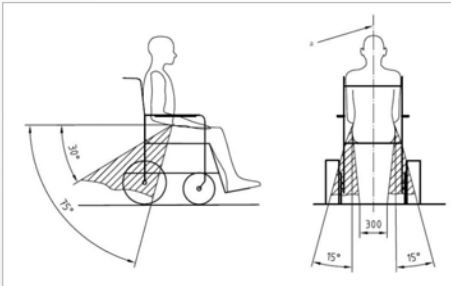

Fig. 30: Positioning the occupant restraint with 4 point strap system

- > The upper torso restraint belt must fit over the shoulder and across the chest as illustrated Fig. 47. Restraint belts must be adjusted as tightly as possible consistent with use comfort.
- > Restraint belt webbing must not be twisted when in use.
- > Care should be taken when applying the occupant restraint to position the seatbelt buckle so that the release button will not be contacted by wheelchair components during a crash.

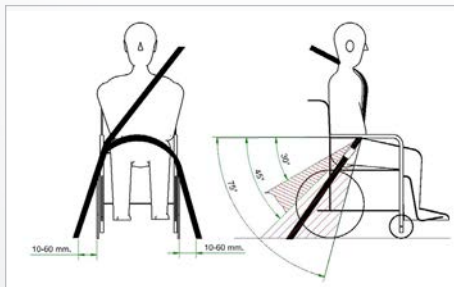



Fig. 31: Positioning the occupant restraint for use with dahl docking system only

	WARNING
Positioning the occupant restraint for use with Dahl docking system only	
<ul style="list-style-type: none"> > When using wheelchair with Dahl docking system, the floor anchorage points for occupant restraint should be located 10 - 60 mm outside wheels, on each side. The pelvic belt must be worn low across the front of the pelvis - so that the angle of the pelvic belt is within the optional or preferred zone of 30° - 75°. As shown a steeper (greater) angle within the preferred zone, 45° - 75° is desirable i.e. closer to, but never exceeding 75° degrees. 	

13.5 Dahl Docking Systems Assembly

According to ISO 7176-19:2008, the Dahl Docking Station MK II and VarioDock™ are suitable for power wheelchair models PR50, PR 40, PR 35S, PR 35, PR piccolo, PR Biolution und PR Heavy Duty duty from Paravan.

The following instructions explain how to assemble the Dahl Docking Station MK II and VarioDock™ on the wheelchair, using the PARAVAN adaption kit. Please also refer to Dahl Engineering's instructions for vehicle installation, use and maintenance.



The operation of the electric wheelchair without faults or malfunctions can only be guaranteed if the knowledge gained from these assembly instructions is observed and implemented. PARAVAN GmbH assumes no liability or warranty for damage or operating faults resulting from non-compliance with these assembly instructions or from modifications to the electric wheelchair.

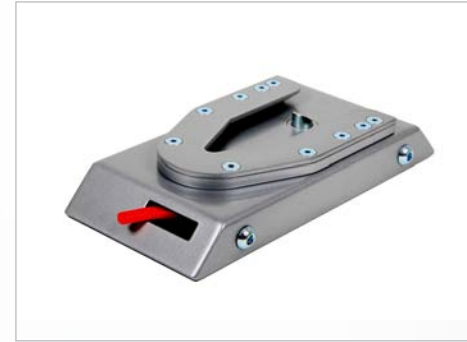

Fig. 32: Dahl docking system



WARNING

Risk of injury through incorrect handling of the batteries.

Damage to property through incorrect handling of the batteries.

- > Handle with special care.
- > May only be connected and disconnected by qualified personnel.
- > Keep away from fire.
- > Dispose of damaged batteries properly.

13.5.1 Content of Dahl docking stations



Fig. 33: Content of Dahl Docking Station MK II standard set # 501750



Fig. 34: Content of Dahl VarioDock™ standard set # 503600

13.5.2 Attaching the Dahl locking plate to the wheelchair

An additional wheelchair-specific adaptation kit is required for mounting the Dahl locking plate. It contains special nuts and plastic spacers to be fitted inside the battery box.

DAHL Docking Station Installation Kit Locking Plate 503125 (PV art. no.: 000043535) and DAHL adaptation set for DAHL Docking station 502064 (PV art. no.: 000044508):

- ① Countersunk screw with Torx TX27 - ISO 14581 M8x35 14.9 (PV art. no.: 000043534)
- ② Locking plate with screws for docking station 10069 (PV-Art.-No.: 000020667)
- ③ 8 mm intermediate piece for locking plate for 10069 DAHL (PV art. no.: 000010131)
- ④ DAHL spacer 502071 (PV art. no.: 000044507)
- ⑤ DAHL nu 500759 (PV-Art.-Nr.: 000044506)

To install the Dahl locking plate, use the DAHL Adaptation kit, article 502064.

- To mount the adapter set you need a Torx wrench TX 27. Tighten the Torx screws with a torque of 16-18 Nm.

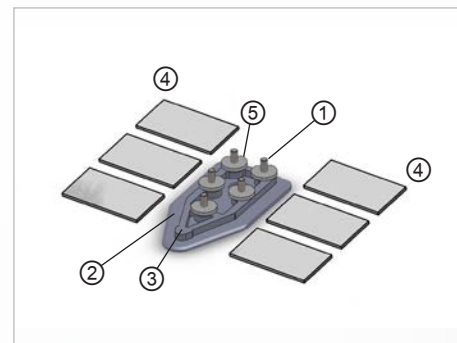

Fig. 35: Dahl Adaptationkit for Dahl Docking Station



Fig. 36: Torx TX 27
Parking and storing the PR 35S

The cover must first be removed to attach the Dahl docking station to the Paravan wheelchair.

- > To remove the cover, loosen the six knurled screws ①. If a main disconnect switch is installed on the rear panel, first remove the key of this switch ②.
- > Remove the rear fairing ③, as well as the side fairings. The order in which these are removed is not important.
- > To open the cover of the battery box, the two front hexagonal screws must be removed with a wrench with a width across flats of 10mm. Afterwards the battery box can be tilted backwards over the hinges - caution: here the whole weight of the structure rests on the lid!

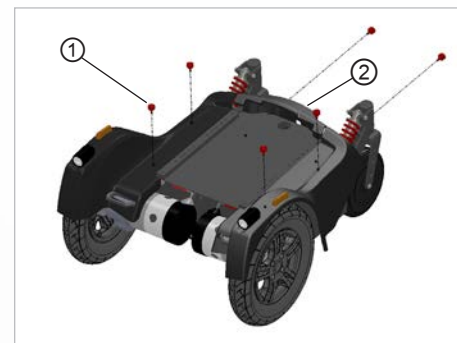

Fig. 37: Knurled screws Paravan

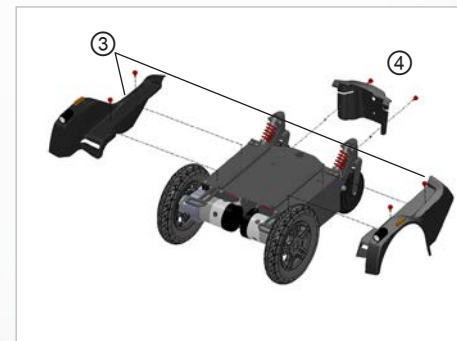

Fig. 38: Rear and side covers Paravan

13.5.3 Attaching the Dahl locking plate to the wheelchair

Removing the batteries:

- Disconnect the main cable plug on the left and right side of the batteries.
- Remove the left and right batteries.



Fig. 39: Main cable battery

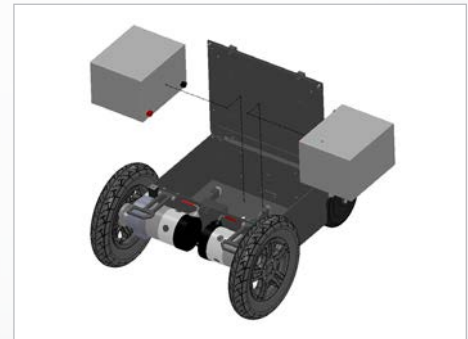

Fig. 40: Removing the batteries

Mounting DAHL system:

- > Position the locking plate 503125 on the bottom of the wheelchair. The holes for positioning are already provided in the battery box.
- > Fasten the locking plate inside the battery box with the adaptation set 502064 and screw the five countersunk screws from below with the DAHL nuts 500759. Adjust the height of the locking rail (1.2).
- > Additional intermediate pieces (1mm, 2mm, 3mm, 8mm, 10mm) may be required. The fine adjustment is done when adjusting the wheelchair at the DAHL docking station in the vehicle. Finally, glue the six spacers 502071 to the bottom of the battery box so that the batteries lie flat when inserted and cannot slip.
- > Once you have adjusted the height of the locking rail, screw in the pan-head screws medium tight with a screw lock. If using the power height adjustable Dahl VarioDock, additional spacers will not be needed for adjusting the height.

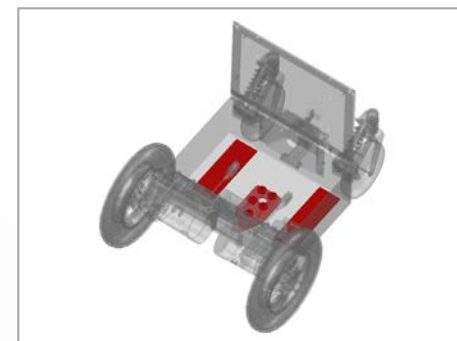

Fig. 41: Position of the Dahl system

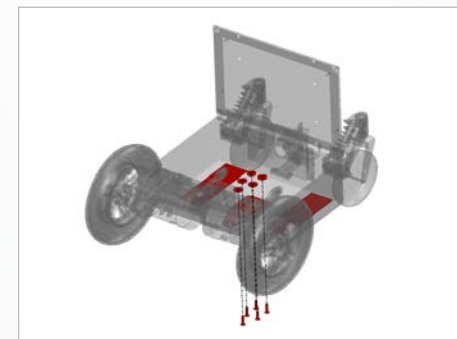

Fig. 42: Fastening of the Dahl system

After the Dahl system has been attached to the wheelchair chassis, reinsert the batteries and reattach the panelling in reverse order.



The PARAVAN adapter kit can also be pushed further forwards or backwards and fastened accordingly, depending on the position of the counterpart in the vehicle.



Installation of the Dahl Docking systems in the vehicle: Only professional companies in the business of converting or building wheelchair accessible vehicles can order the docking system from Dahl Engineering. A qualified and experienced technician must carry out the installation. Dahl Engineering can provide vehicle specific installation instructions for a large range of vehicles, which must be respected by the fitter. Please contact Dahl Engineering for further information about approved vehicles and fitting positions.

To attach the Dahl Docking Station to the PR 35S, use the screws provided.

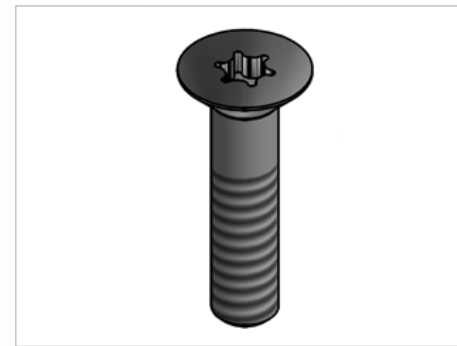

DANGER

Potential risk of injury or serious injury or death due to use of incorrect screws.

- > Use the screws provided.
- > Do not use any other screws than those supplied from Dahl Engineering (part no. 502800 which is quality 14.9 with torx 27 key). Standard screws will not be strong enough in the event of a collision.

13.5.4 Description of the Dahl Docking system functions

- ① Dahl Docking station
- ② Lock plate and spacer
- ③ Lock pin
- ④ Red LED
- ⑤ Green LED
- ⑥ Control panel
- ⑦ Release button
- ⑧ Manual emergency release lever
- ⑨ Manual operating lever

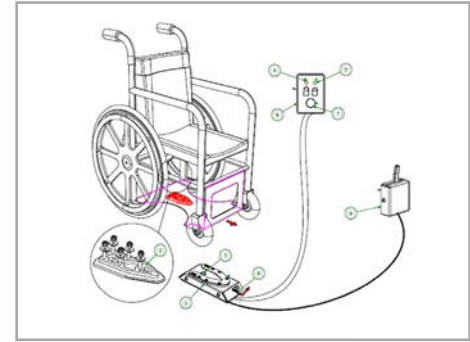

Fig. 43: System functions Dahl



Please refer to Dahl Engineerings installation and user guide for height adjustable VarioDock™ system.

13.5.5 Securing the wheelchair in the docking station

- Maneuver the wheelchair slowly and in a uniform direction over the docking station. The lock plate under the wheelchair helps to guide the wheelchair into place in the docking station. When the lock plate is fully engaged in the docking station, a spring-action locking pin automatically secures the lock plate.
- The docking station is equipped with a control switch that indicates whether the lock plate is correctly secured in the docking station. As soon as the lock plate comes into contact with the locking pin, a warning tone will sound (a high-pitched howl), and the red diode/lamp (LED) in the control panel will light up until the lock plate is either fully engaged or else the wheelchair is removed from the docking station.
- As an indication that the wheelchair is properly secured, the warning tone will cease, the red lamp (LED) in the control panel will go out and the green lamp (LED) will light up.
- Do not forget to buckle up for driving.



Please refer to Dahl Engineerings installation and user guide for height adjustable VarioDock™ system.



DANGER

Potential risk of injury or serious injury or death! Do not move the vehicle:

- > Whilst the wheelchair is being maneuvered into position in the docking station
- > If the wheelchair and user are not correctly secured.
- > If the warning tone sounds and/or the red warning lamp (LED) in the control panel flashes or is lit!

Always check if the lock plate is properly engaged in the docking station by trying to reverse the wheel chair out of the docking station before moving the vehicle. (It must not be possible to reverse out of the docking station without pressing the red release button in the control panel).

13.5.6 Release from the docking station

- When the vehicle has been brought to a halt, remove the safety belt.
- To unlock commence by driving the wheelchair forward to release pressure on the lock pin.
- Press the red release button in the control panel. The locking pin will be triggered/ released for approx. 5 or 8 seconds, after which the locking pin is automatically locked/activated again.
- Move the wheelchair away from the docking station within this 5 or 8 second period. Do not attempt to reverse out of the docking station until the red LED on the control module, which indicates the unlock position, has been illuminated.



Please refer to Dahl Engineering's installation and user guide for height adjustable VarioDock™ system.

 WARNING	
Attempting to reverse the wheelchair before the red LED has been illuminated will result in blocking the docking stations locking mechanism, which makes it impossible to reverse. If this happens repeat above unlocking procedure.	

13.5.7 Manual release in case of electric failure

A manual emergency release is located at the front edge of the docking station.

- Move wheelchair forward to remove the pressure on the lock pin and push the red release arm to one side and hold it there while the wheelchair moves away.
- A cable-activated manual operating lever can also be fitted (accessory). The red release arm is also pushed to one side and should be held there whilst the wheelchair moves away.

If the described manual release procedures fails, an emergency release tool made from red plastic comes with each docking station.

- Move wheelchair forward to remove the pressure on the lock pin
- Place the emergency release tool in the gap between the locking plate and the docking station.
- Push the release tool and wheelchair forward until the locking pin has been forced down - after which the wheelchair can reverse out of the docking station.
- Please also refer to Dahl Engineering instructions for installation, use and maintenance for Dahl Docking Station MK II and VarioDock™ systems.



Fig. 44: Manual release step 1

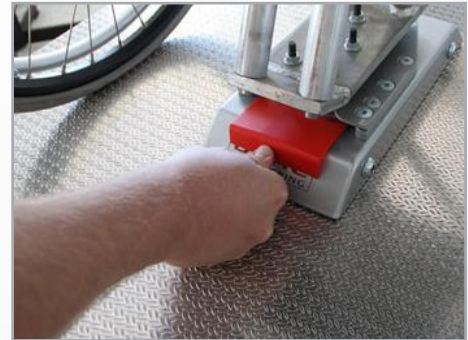

Fig. 45: Manual release step 2

14. Controls

14.1 Control panel R-NET CJSM2

14.1.1 Overview of the control elements



Fig. 46: Control panel R-NET CJSM2

With the control panel (joystick) built into your power wheelchair, you can control all of the power wheelchair's driving, steering and braking processes. All additional functions which are equipped with displacement motors, such as the lifting arm and the sitting functions, must also be operated via the control panel.

- > "On/off" key ① Selection of profile (movement levels)/mode (seat functions)
- > "Direction indicator, right/left" keys ②
- > LCD diagnostic LED brightness sensor ③
- > Display ④ (colour)
- > MODE key ⑤ for switching function – drive program/seat functions
- > PROFILE key ⑥ (selection of movement levels)
- > Joystick ⑦ (determines direction of travel)
- > "Horn" key ⑧
- > Function key ⑨ for selecting/drilling down to movement levels
- > "Hazard lights" key ⑩
- > "Light" key ⑪
- > Charging status indicator for storage battery ⑫

General

Information

Prepare

Operate

Help

Technology

14.1.2 Status display

The function keys are used to select the specific functions displayed in the assigned fields on the display.

Symbols of the status indicator:

- Charging status of the storage batteries ①
- Direction indicator, left ②
- "On/off" light ③
- System status ④ ("tortoise" → speed control active)
- Direction indicator, right ⑤
- Time ⑥
- Hazard lights "on/off" ⑦
- Current seat function / Current driving profile ⑧



Symbols ② + ⑤ play an active part in the "hazard lights" function!



Fig. 47: Function keys



Fig. 48: Status display

14.1.3 Start, switch off



Fig. 49: Speed control (tortoise) active

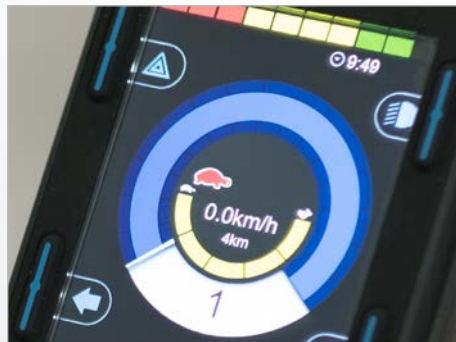

Fig. 50: „On / off“ key

Start

Push the "on/off" switch ① upwards.

- > The status display briefly flashes and the last selected function in terms of movement level / seat function is shown.
- > Press the switch ① downwards again to:
 - > - Select movement levels 1 to 5
 - > - Then switch to the seat functions

Switch off

Push the "on/off" switch ① upwards.

- > The power wheelchair switches itself off (assuming it is already switched on).

14.1.5 Switch direction indicator on and off

Press key ① or ② for the respective direction indicator, left or right.

- The selected direction indicator will flash.
- Press once more → direction indicator switches off.



Fig. 52: Turn signal right / left

14.1.4 Switch light on and off

Press the key ① for the "light on" function.

The lighting installation switches itself on and the light symbol lights up blue.

Press once more:
→ Light off



Fig. 51: Light on and off

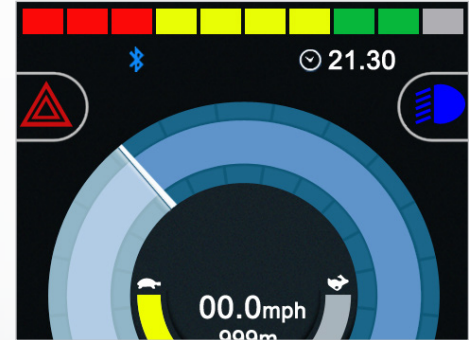

Fig. 53: Light symbol (colour)

14.1.6 Switch hazard lights on and off

Press the "hazard lights" key ① for the "hazard lights on" function.

- The hazard lights switch themselves on, while the hazard lights symbol flashes red and both direction of travel symbols flash green.
- Press the key again → The hazard lights / hazard lights symbol switch themselves off.



Fig. 54: Hazard lights on / off

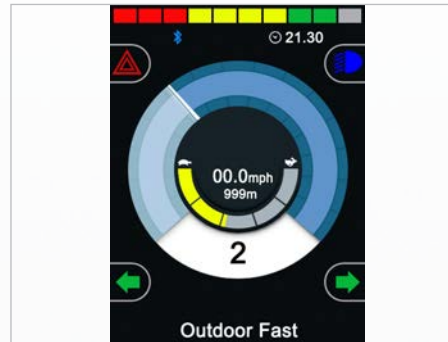

Fig. 55: Symbols (colour)

14.1.7 Driving functions overview



Fig. 56: Driving functions



Fig. 57: Charging status indicator (driving function blocked)

Overview of the driving functions shown on the display of the control panel during driving, steering and braking actions of the power wheelchair.

- > Selected drive program/movement level ①
- > Respective setting (having drilled down) for the selected movement level (1 to 5) fast/slow ②
- > ③ (Profile) key for switching to a higher or lower drive program (1 to 5).
- > Key ④ to change speed in the drive program. Drilling down the respective drive program.
- > Display of the current speed (km/h) ⑤
- > "Trip" display in kilometres ⑥

Display turns black when a charging device is connected.

- > If the wheelchair is switched on, the charging status indicator is the only thing shown.
- > First connect the charging lead for the charging device at the joystick, then plug the power cable for the charging device into the socket.



If the power wheelchair is being charged via the charging socket on the control panel, driving mode is automatically blocked.

14.1.8 Select drive program, drive

The power wheelchair must be in driving mode.

- > The last selected drive program is shown on the display (profiles 1 to 5). Drive profiles 1 to 5 are further divided into 5 levels once you drill down.

Press the switch upwards ① or downwards ② to switch to a higher or lower sub-level.

- > The selected drive program and sub-level will appear on the display.

Push the joystick in the direction in which you wish to travel.

- > The power wheelchair moves in the selected direction.
 - ① Move forwards
 - ② Turn to the right
 - ③ Move backwards
 - ④ Turn to the left



See section "3 Safety notes"



Fig. 58: Select drive program



Fig. 59: Joystick travelling direction

14.1.9 Electrical seat adjustment



Fig. 60: Example: Display of seat functions

Use the MODE key to switch from the drive program to the seat functions. Select the desired seat function by moving the joystick “← left/right →”.

> The adjustment functions menu will appear on the display.



Only the released or available functions can be selected.

To make the desired setting:
adjust the seat, seat position, backrest, tilting of seat, angle for legs and lying/standing function via the joystick (by moving it forwards or backwards).

Switch back to the drive program with the Profile key.

> The power wheelchair is ready to drive.



See section "3 Safety notes"

14.1.10 Set time/date

Press and hold the "hazard lights" key to access the "Settings" menu.

> The special functions menu will appear on the display.

Move the joystick → left/right to access the options "year, month, date, day of the week, hours and minutes". Select the desired option by moving the joystick "← left/right →".

Move the joystick "↑ up/down ↓" to select exactly the setting you want. To save and quit the menu, go to "Quit" and close it by moving the joystick "↑ up/down ↓".



Fig. 61: "Set time" function menu



Fig. 62: Setting the time and date

14.1.11 Show/hide clock, configure 12h/24h display



Fig. 63: Set clock to visible/invisible

Select the program function:

- > Press and hold the "hazard lights" key.
- > The "Settings" menu appears.
- > Use the joystick to select "Set time". Move the joystick "← left/right →".
- > Select "12h/24h display" or "Off" by moving the joystick "← left/right →".
- > To save → quit the program. Move the joystick "← left/right →".

14.1.13 Adjust display brightness

Select the program function:

- > Press and hold the "hazard lights" key.
- > Select "Back lighting" from the settings.
- > Select the intensity of the lighting (0 to 100% in 10% stages) by moving the joystick "← left/right→".
- > To save → quit the menu.



Fig. 64: Setting the display brightness

14.1.12 Adjust display brightness, automatic (recommended)



The display brightness is automatically adjusted to lighting conditions by the factory. Menus may be arranged slightly differently, depending on the software version.

Select the program function:

- > Press and hold the "hazard lights" key.
- > Select "Auto Backlight" from the settings.
- > Select "On/Off" by moving the joystick "← left/right →".
- > To save, quit the menu.



Fig. 65: Autom. display brightness

14.1.14 Block the controls (with the wheelchair switched on)

- Turn the control panel off and press and hold the ON/OFF button ① until you hear a beeping sound
- Move the joystick forwards until you hear a beeping sound
- Move the joystick backwards until you hear a beeping sound
- Immobiliser is activated



Fig. 66: Blocking the controls

14.1.15 Release the controls (with the wheelchair switched off)

- Switch on → and a "padlock symbol" appears .
- Move the joystick forwards until you hear a beeping sound
- Move the joystick backwards until you hear a beeping sound
- The "Functions" menu is now available – the last function selected is shown



Fig. 67: Lock symbol

14.2 Control panel R-NET CJSM-L

14.2.1 Overview of the control elements



Fig. 68: Control panel R-NET CJSM-L

With the control panel (joystick) built into your power wheelchair, you can control all of the power wheelchair's driving, steering and braking processes. All additional functions which are equipped with displacement motors, such as the lifting arm and the sitting functions, must also be operated via the control panel.

- > "On/off" key ①
- > "Direction indicator, right/left" keys ②
- > Display showing the signal currently active (light, indicator) ③
- > Display ④ (colour)
- > MODE key ⑤ for switching function – drive program/seat function
- > PROFILE key ⑥ (selection of movement levels)
- > Joystick ⑦
- > "Horn" key ⑧
- > Function key ⑨ for selecting/drilling down to movement levels
- > "Hazard lights" key ⑩
- > "Light" key ⑪
- > Charging status indicator for storage battery ⑫

14.2.2 Status display

The function keys are used to select the specific functions displayed in the assigned fields on the display.

Symbols of the status indicator:

- Charging status of the storage batteries ①
- Direction indicator, left ②
- "On" light ③
- System status ④ ("tortoise" → speed control)
- Direction indicator, right ⑤
- Time ⑥
- Hazard lights ⑦



Symbols ② + ⑤ play an active part in the "hazard lights" function!



Fig. 69: Function keys



Fig. 70: Status display

14.2.3 Start and switch off



Fig. 71: "On / off" key

Start

Push the "on/off" switch ①.

- > The last selected function in terms of movement level / seat function is shown.

Switch off

Push the "on/off" switch ①.

- > The power wheelchair switches itself off (assuming it is already switched on).



Fig. 72: Speed control (tortoise) active

14.2.4 Switch light on and off

Press key ① or ② for the respective direction indicator, left or right.

- The selected direction indicator will flash.
- Press once more → direction indicator switches off.

14.2.5 Switch direction indicator on and off

Press the key ① for the "light on" function. The lighting installation switches itself on and the light symbol lights up blue. Press once more: "light off".



Fig. 73: Light on and off



Fig. 74: Turn signal right / left



Fig. 75: Light symbol (colour)

14.2.6 Switch hazard lights on and off

Press the "hazard lights"key ① for the "hazard lights on" function.

- The hazard lights switch themselves on, while the hazard lights symbol flashes red and both direction of travel symbols flash yellow.
- Press the key again → The hazard lights / hazard lights symbol switch themselves off.



Fig. 76: Hazard lights on / off



Fig. 77: Symbols (colour)

14.2.7 Driving functions overview



Fig. 78: Driving functions

Overview of the driving functions shown on the display of the control panel during driving, steering and braking actions of the power wheelchair.

- > Selected drive program/movement level ①
- > Maximum speed in the selected drive program ②
- > Key ③ to switch to a higher (+) or lower (-) drive program
- > Key ④ to change speed in the drive program
- > Display showing "trip" in kilometres and current speed (km/h) ⑤

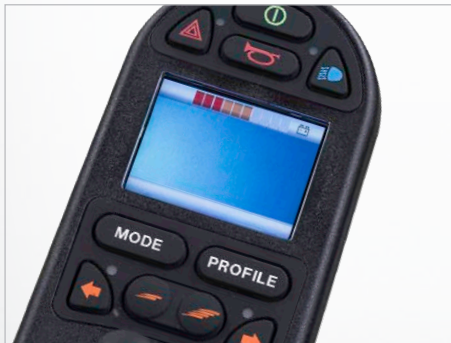

Fig. 79: Driving function blocked

Display is blank when a charging device is connected.

- > If the wheelchair is switched on, the charging status indicator is the only thing shown.
- > First connect the charging lead for the charging device at the joystick, then plug the power cable for the charging device into the socket.



If the power wheelchair is being charged via the charging socket on the control panel, driving mode is automatically blocked.

14.2.8 Select drive program, drive

The power wheelchair must be in driving mode.

- > The last selected drive program is shown on the display.

Press the profile key ① to select/switch to one of the 5 movement levels (profiles).

- > The selected drive profile will appear on the display.

Press the relevant key to select a higher ② or lower ③ maximum end speed in the respective drive profile.

- > The preference within the drive profile will appear on the display.

Push the joystick in the direction in which you wish to travel.

- > The power wheelchair moves in the selected direction.

- ① Move forwards
- ② Turn to the right
- ③ Move backwards
- ④ Turn to the left



See section "3 Safety notes"



Fig. 80: Select drive program



Fig. 81: Joystick travelling direction

14.2.9 Electrical seat adjustment



Fig. 82: Display of seat functions

Use the "Mode key" to switch from the drive program to the seat functions. Select the seat function by moving the joystick "← left/right →".

> The respective seat function will appear on the display.



Only the released or available functions can be selected.

Adjust the seat via the joystick (push forwards or backwards).

> The seat carries out the desired function.

Switch back to the drive program with the mode key.

> The power wheelchair is ready to drive.



See section "3 Safety notes"

14.2.10 Set time/date

Press and hold the "slower" ① and "faster" ② speed keys to access the "Settings" menu.

> The special functions menu will appear on the display.

Move the joystick → right to access the options "year, month, date, day of the week, hours and minutes". Select the desired option by moving the joystick "← left/right →".

Move the joystick "↑ up/down ↓" to select exactly the setting you want. To save and quit the menu, go to "Quit" and close it by moving the joystick "↑ up/down ↓".



Fig. 83: "Set time" function menu



Fig. 84: Setting the time and date

14.2.11 Show/hide clock, configure 12h/24h display



Fig. 85: Set clock to visible/invisible

Select the program function:

- > Press and hold the keys ①+②
- > The "Settings" menu appears.
- > Use the joystick to select "Display time".
- > Select "12h/24h display" or "Off" by moving the joystick "← left/right →".
- > To save → quit the program.

14.2.12 Adjust the display background and brightness

Select the program function:

- > Press and hold the "slower" ① and "faster" ② speed keys.
- > Select "Back lighting" from the settings.
- > Select the intensity of the lighting (as a percentage) by moving the joystick "← left/right →".
- > To save → quit the menu.

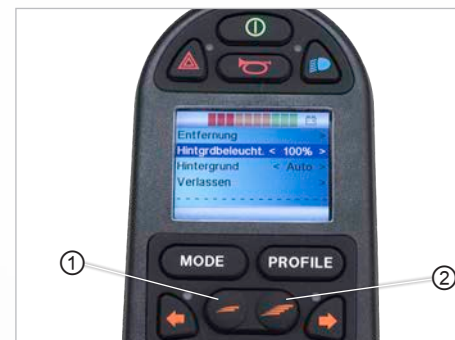

Fig. 86: Setting the display brightness

14.2.13 Adjust display brightness

Select the program function:

- > Press and hold the "slower" ① and "faster" ② speed keys.
- > Select the preferred option by moving the joystick "← left/right →".
- > To save, quit the menu.

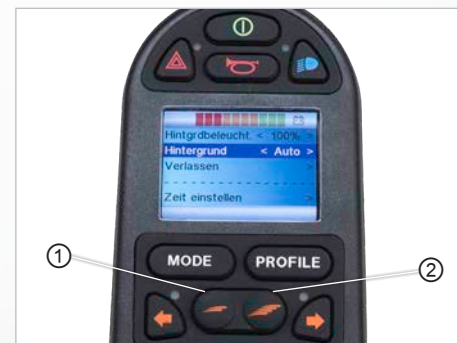

Fig. 87: Setting the display background

14.2.14 Block the controls (with the wheelchair switched on)

- Turn the control panel off and press and hold the ON/OFF button ① until you hear a beeping sound
- Move the joystick forwards until you hear a beeping sound
- Move the joystick backwards until you hear a beeping sound
- Immobiliser is activated



Fig. 88: Blocking the controls

14.2.15 Release the controls (with the wheelchair switched off)

- Switch on → and a "padlock symbol" appears .
- Move the joystick forwards until you hear a beeping sound
- Move the joystick backwards until you hear a beeping sound
- The "Functions" menu is now available – the last function selected is shown.



Fig. 89: Controls blocked – block symbol

15. Moving out of the PR 35S seat

For your own safety, the instructions below must be followed in order to enable you to move out of the PR 35S independently:

- > You should be able to safely carry your own weight.
- > You should be able to push yourself off from the PR 35S with both arms simultaneously using the same amount of strength.
- > You should have a safe position to support yourself, one from which you cannot slip.
- > You should have practised everything often enough in the presence of another person.
- > You should consider all eventualities in case you fall on the floor and there is no one present with you.



We recommend that you enlist the help of another person. However, you should point out the dangers to this person. In all cases, discuss the implementation process together. Never support yourself on the control panel, the PR 35S could be accidentally activated and would then start following uncontrolled commands.



If you want to move to the seat of another PR 35S, the brake lock release lever must be set to "**LOCK**" (upwards) and the PR 35S must be switched off.



See section "12.9.1 Operation of the brake lock release lever (emergency release)"

15.1 Procedure when moving sideways out of the seat

When moving sideways out of the seat, proceed as follows:

- Position the PR 35S sideways
- Adjust the seat to the required height
- Turn off the PR 35S
- Fold up ① footrests
- Swing ② armrest upwards
- Move from the seat



Fig. 92: Move from the seat, footrests



Fig. 93: Move from the seat, armrest

If you want to use and operate the PARAVAN PR 35S in line with its intended purpose, you need to comply with the recommended annual maintenance plan that was designed for the power wheelchair. All driven parts and in particular the functional unit are designed to ensure low-maintenance and fault-free operation of the PR 35S.

However, in order to guarantee its perfect functioning, the PR 35S must nonetheless:

- > be handled with care,
- > be kept clean,
- > be serviced periodically on an annual basis.

16.1 Service partner

If problems occur, please contact your medical supply store or your dealer, or PARAVAN GmbH directly.



In order to have maintenance work carried out, please contact your medical supply store or your dealer, or PARAVAN GmbH directly. Maintenance and servicing works must only be carried out by trained persons.

16.2 *Cleaning and care*



Never use a high-pressure cleaner to clean the PR 35S. Avoid contact of the electronic parts with water.

Regular care and maintenance will prevent unnecessary wear and damage to your PARAVAN power wheelchair. Switch off the power supply before cleaning the wheelchair.

16.2.1 Metal surfaces

The high-quality powder coating ensures optimum corrosion protection. Use a soft cloth or sponge, warm water and a mild cleaning agent for normal cleaning. Carefully wipe with a damp cloth and then dry. Treat abrasion marks on semi-matt surfaces with soft wax. Follow the instructions of the soft wax manufacturer. Abrasion marks and scratches can be removed from shiny surfaces with car polish. You can use liquid car polish or pastes. Apply soft car wax after polishing to restore the original surface shine. Spray the covers of the springs on the rear wheel suspensions regularly with a commercially available multi-function oil or lubricant.

16.2.2 Plastics

For normal cleaning of plastic surfaces, use a soft cloth, mild detergent and warm water. Rinse thoroughly and dry the surfaces with a soft cloth. Do not use solvents or abrasive household cleaners.

16.2.3 Upholstery, fabric and vinyl

For normal cleaning of the upholstery, use lukewarm water and a mild, non-abrasive soap. Use a soft cloth or brush. Wipe any water or soapy water residue dry with a clean, dry cloth. Allow the surface to dry.

Repeat this process for stubborn dirt or stains. Ink stains may be removed with soap and water followed by treatment with isopropyl alcohol.

Do not use cleaning methods other than those listed here. Other cleaning methods may attack and damage the vinyl, which may void the wheelchair's warranty. If necessary, you can remove the cover before cleaning. For more information, see the washing instructions on the upholstery.

16.2.4 Disinfection

Spraying and washing with tested and approved disinfectants is permitted. A current list of all approved disinfectants can be found on the website of the Robert Koch Institute at www.rki.de.

17. *Disposal and environmental protection*

General

Information

Prepare

Operate

Help

Technology

The PR 35S itself and its individual components are technically durable. In most cases, recyclable and harmless raw materials are used for its design and manufacture. After it has been decommissioned, the PR 35S is ideally suited to undergo proper recycling processes and environmentally friendly disposal procedures.



National and regional waste disposal provisions must be complied with.

The PR 35S can be dismantled into the following main parts for the purpose of recycling:

- metals,
- plastic or composite materials,
- electronic waste,
- storage batteries.

A top-end recycling procedure in accordance with the type and character of the waste should be sought ("Closed Substance Cycle and Waste Management Act"). This is economically viable if the costs associated with recycling are not disproportionate to the costs which would be incurred for waste disposal.

17.1 Packaging material

The packaging consists of largely recyclable material which is harmless to the environment, such as:

- > wood, e.g. pallets or outer packaging,
- > metal, e.g. tightening straps,
- > bubble wrap.

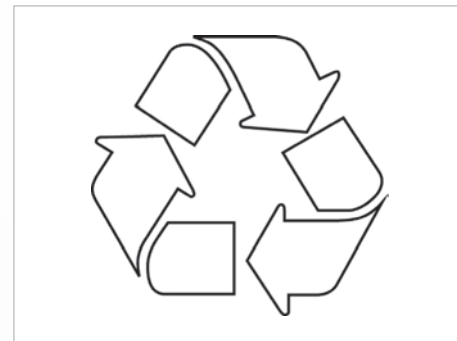

Fig. 94: Recycling



Take advantage of the opportunity to recycle the packaging in an environmentally-friendly way. Recycling of rubbish should take priority over its disposal.

17.2 Note on corrosion protection

All metal parts on your PARAVAN power wheelchair are corrosion-protected, e.g. by hot-dip galvanising, electroplating and powder-coated surfaces.



Please observe the cleaning instructions see „16 Maintenance and servicing“

17.3 **Recommissioning**

If the PR 35S has been out of service for a long time, the following steps must be carried out before it is recommissioned:

- > check protective devices, repair if necessary,
- > complete maintenance or review,
- > complete cleaning.



Before it can be operated again, the PR 35S must be completely cleaned and approved for use after a thorough inspection by a service technician authorised by PARAVAN GmbH.



e „16 Maintenance and servicing“

17.4 *Information regarding transfer of the product*

If you give or sell the PARAVAN PR 35S standing wheelchair to another person, you must also pass on all the necessary technical documents for safe handling and operation, such as:

- > operating instructions,
- > proofs of maintenance

to the new user.



Please see „16 Maintenance and servicing“

18. Troubleshooting

18.1 Status indicator on the control panel

Error message	Meaning
Centre joystick / Joystick zentrieren	The most common cause of this error is that the joystick is not centred when the control system is switched on. "Joystick off-centre" will appear on the display for five seconds. If the joystick is not released within this time, an error will be generated. Please ensure that the joystick is centred and then switch the control system on. When switching on the control system, make sure that you do not touch the joystick button with your hand.
Low battery / Batteriestand niedrig	This message appears when the control system detects that the battery voltage has dropped below 16 V. Check the state of the batteries and the connections in the control system. High battery / Hohe Batteriespannung This message appears when the control system detects that the battery voltage has risen above 35 V. The most common reason for this is that you have overcharged the battery or there is a bad connection between the control system and the batteries. Check the state of the batteries and the connections in the control system.
System lock active / Sperre aktiv	This message appears when one of the blocking inputs is active and locked. Switch the control system off and on again. This will remove the system lock and may get rid of the error. Check all cables and switches on the corresponding blocks.

General

Information

Prepare

Operate

Help

Technology

Error message	Meaning
Brake error / Bremsen	<p>This message appears when the control system detects a problem with the magnetic brakes or their connections. Check the magnetic brakes, cables and connections in the control system. Check that the motor brakes have not come uncoupled.</p> <p>Motor error / Motorfehler This message appears when the control system detects that the connection to a motor has been interrupted. Check the motors, cables and connections in the control system.</p>
Gone to sleep / Ruhemodus	<p>This message appears when the control system has been inactive for longer than the [time] period defined by the "SleepTimer" parameter.</p> <p>Gyro disconnected / Gyro ni. angeschl This message appears when the control system detects that the gyro module is no longer connected. Reconnect the gyro module and restart the system.</p> <p>Bad cable / Kabelfehler This message appears when the control system detects an error in the cabling that enables the modules to communicate with one another. Check whether the cables or connections have been interrupted or squashed/jammed. If there is any visible damage to the cables, replace them and switch the control unit off and on again. Please speak to customer service about any replacements you may need.</p>

19. **Electrical system**

19.1 **Automatic fuses**

The PARAVAN PR 35S standing wheelchair is equipped with an automatically triggering fuse and an overload protection device. These are described in more detail below:

- > Main fuse: This protects the complete electrical system in the event of overloading by PR 35S electrical consumers – the response is an instant and complete electrical shut-down of the entire power wheelchair.



See section "20.2 Main fuse"

- > Overload protection: The power generated during downhill travel is diverted into the storage batteries. If the storage batteries were already charged, the safety system switches to emergency stop.



See section "20.3 Overload protection"

19.2 Main fuse



The main fuse is located at the rear of the power wheelchair.



An active (triggered) main fuse is indicated by the swung out green lug.

19.2.1 Resetting a triggered main fuse

- > Push the lug ① of the active main fuse ② back into its original position ③. & The lug must audibly or visibly lock into place.
- > The PR 35S is ready for operation again.

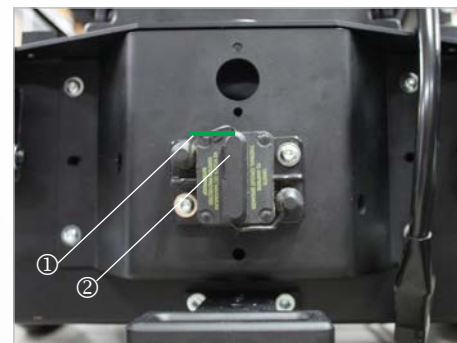

Fig. 95: Main fuse, active

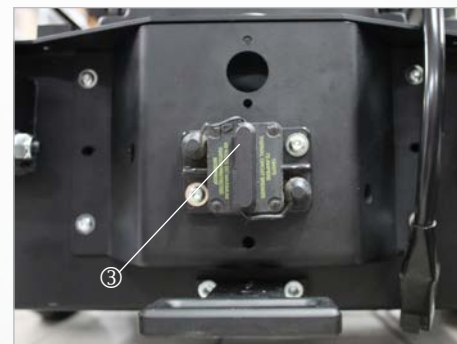

Fig. 96: Main fuse

19.3 *Operating the battery disconnect switch*

By activating the battery disconnect switch, the installed 2x12 V AGM batteries are disconnected from the power circuit of the wheelchair to ensure safe transport.

The disconnect switch is located on the right rear part of the chassis below the panelling. Turning and removing the disconnect key will disconnect the batteries so that the wheelchair cannot be started up even by pressing the on switch on the joystick.

Completely fold up the wheelchair and ensure that nothing can be damaged during transport. Switch off the control unit.

Now turn the key 90° and remove it, now no more adjustment can be made. The chair can now only be pushed by disengaging the mechanical brake on the motor. After securely lashing the wheelchair, lock the brakes again.



Fig. 97: *Battery disconnect switch*



Fig. 98: *Battery dicon. switch, inactive*

19.4 Overload protection



While travelling downhill, the generated power is diverted into the storage batteries – the drive motors work like a generator in this case. If you have fully charged your PR 35S before travelling downhill, the security system switches to emergency stop in order to avoid damage to the electrical system (control, electronics, etc.).



Active (triggered) overload protection is indicated by gradual braking until the PR 35S comes to a standstill.

19.4.1 Reset the triggered overload protection:

- > Switch on the power generators, e.g. lighting. The generated excess power is now immediately used again.
- > The PR 35S is ready for operation again.

19.5 **Connection option for auxiliary units**



The PARAVAN PR 35S offers the option of connecting different auxiliary units with a voltage of 12 volts or 24 volts to the PR 35S on-board power supply.

If you require special equipment (e.g. a respirator) for this connection, please contact PARAVAN GmbH. The external connections are individually adjusted for the respective consumer and the cable harness is cut to size or moved in position.

19.6 The lighting installation

The PARAVAN PR 35S is equipped with a lighting installation featuring LED technology that is fully approved for road traffic. Due to the LED lamps used, the wearing out or maintenance of this installation is practically impossible/unnecessary.

To switch on the lighting installation, proceed as follows:

- > Select menu in the control unit.
- > Switch on the lighting installation.

 See section "15 Control"

Parts of the lighting installation:

- > LED front headlamps ①
- > LED direction indicator ②
- > LED rear light ③



Fig. 99: Illumination at the front



Fig. 100: Illumination at the rear

19.7 **Maintenance-free storage batteries**

Your PARAVAN PR 35S is equipped with high quality and powerful storage batteries. These maintenance-free storage batteries are completely sealed. Refilling or topping up the electrolyte (battery acid) is therefore not intended or possible.

The charging status or the capacity of the storage batteries can be read on the control panel.

- Red zone: low capacity, immediate recharging necessary.
- Yellow zone: energy is still sufficient, recharging if the opportunity arises.
- Green zone: Storage battery fully charged, full capacity.



See section "15 Control"



See section "20.8 Charging the PR 35S"

19.8 Information regarding storage batteries



Sealed storage batteries must never be opened. Opening the storage batteries will result in irreparable damage to them and could lead to a complete power failure.



See section "22.1 Handling sealed storage batteries"



The storage batteries must be recharged after every use (even if they have only been minimally discharged) with the supplied charger. Always connect the charger during periods of non-use of the power wheelchair. The supplied charger automatically switches to "trickle charging" and thus guarantees continuous full use of the storage battery's functions. If you leave the storage batteries uncharged for too long they will deeply discharge and recharging will no longer be possible, meaning the battery should be replaced.



See section "20.8.2. Charger"



When disposing of storage batteries, please observe the current regulations relating to waste disposal. For information regarding these, please contact the responsible city council or municipal authority, or contact a disposal company directly.



See section "18 Disposal and Environmental Protection"

19.9 Charging the PR 35 S



Only charge the storage batteries with the charger supplied by us.



When using the external charging socket, the joystick is deactivated during the charging process. This means that the wheelchair is completely inoperable during the charging process!

Care tips:

- > Always ensure that the storage batteries have full charging capacity.
- > Daily overnight charging is recommended.
- > The PR 35S should be charged for at least 8 hours uninterrupted.
- > The charging cycle ends when the green lamp is lit up.
- > Always connect the charger during periods of non-use (trickle charging).



If you observe these care tips, the performance and service life of the storage batteries will be maximised.



See section "20.6 Maintenance-free storage batteries"



See section "20.7 Information regarding storage batteries"

19.9.1 Procedure for charging the PR 35S



Fig. 101: Plug in the charging cable

- > Turn off the PR 35S.
- > Put the charger on a heat-insensitive surface, e.g. on the footrests.
- > Put the charger plug ① into the charging socket on the control panel.
- > Connect the charger to the power supply & The charging process starts.
- > Check the charging status. & Are the storage batteries at full capacity? The charging process is complete.
- > Disassembly in reverse order.



Terminate the connection between the power at the power socket and the charger.

19.9.2 The charger

The purpose of the charger is to automatically charge the storage batteries. The charger is housed in splash-proof sheet-steel casing. It complies with the guidelines and protection requirements of the:

- Low Voltage Directive 2006/95/EC,
- Electromagnetic Compatibility Directive 2004/108/EC.



Read the operating instructions included separately with the charger.

19.9.3 Installing the charger, installation location

- Only install in dry rooms.
- Do not cover casing openings.
- Ensure sufficient ventilation.
- Do not install near to radiant heaters (e.g. under lamps, on heaters etc.)



During the charging process, put the charger on the foot supports of the wheelchair.



Fig. 102: Set up charger

20. *Technical equipment*

20.1 *Technical data and dimensions*

19.9.4 The average lifespan

We assume an expected average product life of 6-10 years for this product, provided that the product is used within the intended use and all maintenance and service specifications are complied with.

The service life of your product depends on the frequency of use, the environment in which it is used and the care it receives. The service life can be extended by using spare parts.



The stated service life does not constitute an additional guarantee!

20.1.1 Technical Data

Wheelchair versions	
PR 35S	120 to 160 cm body height
Seat adjustment	
Seat height	440 mm
Seat angle forwards (standing function)	90°
Seat angle backwards (tilting)	45°
Backrest angle	8° to 85°
Foot support angle	0° - 90°
Main dimensions	
Width	570 mm
Length	850 mm
Length (footplates folded up)	960 mm

20.1.2 Dimensions

Other special features	
Puncture-proof tyres	Fold-up footplate
Independent leaf spring rear suspension	Footrests with length compensation
Compatible with DAHL docking station	Controls: R-Net
Individual seat pad adjustment	Maintenance-free gel batteries
Electrical equipment	
Storage batteries	2 x 12 Volt / 85 Ah / C20
Lighting	LED direction indicators LED front and rear lights
Range	Approx. 30 km
Chassis / tyres	
Spacer width at the drive axle	490 mm
Spacer width at the rear axle	320 mm
Wheelbase	560 mm
Measurements of front wheel	3.00 - 8 clearance
Measurements of rear wheel	2.50 - 3 clearance

Seat features	
Seat width	27 - 42 cm
Seat depth	33 - 44 cm
Backrest height	34 - 42 cm
Driving features	
Ground clearance	80 mm
Maximum obstacle clearance	71 mm
Turning circle	710 mm
Maximum (upward) climb	12% / 4%**
Maximum (downward) slope / (sitting/standing)	12% / 4%**
Maximum camber (sitting/standing)	12% / 4%**
Speed (sitting/standing)	6km/h* or 10km/h (optional)*
Weights	
Unladen weight (version small / version medium, large)	160 Kg
Maximum load	80 Kg
Operating conditions	
Temperature	10° - 40°
Humidity	20% - 90%
* The maximum range was measured under test conditions. The actual range achieved may vary according to weight, terrain and weather conditions. The HMV version is limited to 6 Km/h.	

Details regarding the pads on the arm supports, seat and rear, description of the frame

Arm support pads	
Pad material:	PV foam
Thickness:	20mm
Compression hardness:	7.2 kPa
Density:	56 kg/m ³
Cover:	BC 12 / Floridas



Seat pads	
Pad material:	PR foam / MOI system
Thickness:	50 - 110 mm
Compression hardness:	-
Density:	340 +/- 25 N
Cover:	Matt black



The seat pad and backrest pad are moulded foam parts and are therefore not measurable in volumetric weight. Moulded parts are measured in accordance with DIN standards. Measurement is made in N.

Details regarding the pads on the arm supports, seat and rear, description of the frame



Back pads	
Pad material:	PR foam / MOI system
Thickness:	30 - 50 mm
Compression hardness:	77 kg/m ³ ± 5%*
Degree of hardness:	340 +/-25 N*
Density:	260 +/- 25 N
Cover:	Matt black

* These are not cut foam cuboids and are therefore foamed as moulded parts. And therefore measured in N in accordance with Din ISO 2439.

Frame	
Pad material:	S2 235 JR / S3 55 M2
Coating:	Galvanisation
Corrosion protection:	Galvanisation



The seat pad and backrest pad are moulded foam parts and are therefore not measurable in volumetric weight. Moulded parts are measured in accordance with DIN standards. Measurement is made in N.

20.2 Spare parts

** When travelling on steep slopes, please do not travel at maximum speed or use the seat height adjustment, tilt or seat length adjustment functions and please exercise particular caution when travelling on uneven surfaces (e.g. grass, gravel, sand, ice and snow)!



See section "3 Safety notes"



Replacing original parts with non-original parts or parts made in the style of the original (copied) is strictly prohibited/forbidden! Only obtain your replacement parts from your dealer or PARAVAN GmbH.



WARNING

Danger of injury for persons operating a PR 35S which does not correspond to the original or delivered condition.

Material damage to the PR 35S through the use of unapproved parts or incorrectly installed parts.

- > Do not make any technical modifications to the power wheelchair.
- > Only operate the PR 35S in its original or delivered condition.
- > Use only original and approved replacement parts.

21. **Electromagnetic compatibility (EMC)**

21.1 **Information regarding electromagnetic compatibility**

- ➔ The installation and maintenance of the device may only be carried out by specialist staff.
- ➔ Only the charging station supplied by the manufacturer may be used.
- ➔ The connector must be securely installed. Electronic components and cables must not be damaged.
- ➔ The use of longer cables lengths can result in increased emitted interference or reduced interference immunity.
- ➔ Only the original accessories supplied by the manufacturer may be used.
- ➔ In special cases, e.g. if highly sensitive equipment is being used in the direct vicinity of the device, additional remedial action might need to be taken so that the electromagnetic interference emission is further lowered below the set limit values.

21.2 Compliance level

The interference immunity levels in accordance with IEC 60601 are fulfilled.

Manufacturer's declaration – electromagnetic interference

The PR 35S is designed to be operated under the electromagnetic conditions specified below. The customer or the user of the device should ensure that it is used under these conditions.

Emission measurements	Compliance	Electromagnetic conditions – guidelines
HF emissions in accordance with CISPR11	Group 1	The PR 35S only uses HF energy for its internal functions. Therefore its HF emissions are very low, and it is unlikely that adjacent electronic devices will be disturbed by these.
HF emissions in accordance with CISPR11	Class B	The device is designed to be used in all set-ups including living areas and those which are directly connected to a public power grid that also supplies power to buildings being used for living purposes.
Emission of harmonics in accordance with IEC61000-3-2	Class A	
Emission of voltage fluctuations/flickers in accordance with IEC61000-3-3	fulfilled	

Table 201 in accordance with DIN EN 60601-1-2, 6.8.3.201

Manufacturer's declaration – electromagnetic immunity

The PR 35S is designed to be operated under the electromagnetic conditions specified below. The customer or the user of the device should ensure that it is used under these conditions.

Interference immunity tests	IEC 60601 – test level	Compliance level	Electromagnetic conditions – guidelines
Electrostatic discharge (ESD), in accordance with IEC 61000-4-2	± 6 kV Contact discharge ± 8 kV Air discharge	± 6 kV Contact discharge ± 8 kV Air discharge	Floors should be made from wood or concrete, or have ceramic tiles. If the flooring is made from synthetic material, the relative humidity must be at least 30%.
Fast transient electric bursts in accordance with IEC 61000-4-4	± 2 kV for power supply cables ± 1 kV for input and output cables	± 1 kV for input and output cables	The quality of the supply voltage should correspond to that of a typical business or hospital environment.
Surges, in accordance with IEC 6100-4-5	± 1 kV differential mode voltage ± 2 kV common-mode voltage	Not usable	The quality of the supply voltage should correspond to that of a typical business or hospital environment.

General

Information

Prepare

Operate

Help

Technology

Voltage dips, short interruptions and fluctuations in the supply voltage, in accordance with IEC 61000-4-11	< 5% UT (>95% dip of UT) for 0.5 periods 40% UT (60% dip of UT) for 5 periods 70% UT (30% dip of UT) for 25 periods < 5% UT (>95% dip of UT) for 5 seconds	Not usable	The quality of the supply voltage should correspond to that of a typical business or hospital environment. If the movanimo user requires continued functionality in the event the power supply is interrupted, it is recommended that the movanimo be connected to an interruption-free power supply or a battery.
Magnetic field in the power supply frequency (50/60 Hz) in accordance with IEC 61000-4-8	3 A/m	3 A/m	Magnetic fields in the mains frequency should correspond to the typical values which are present in a business and hospital environment.
NOTE UT is the mains voltage before using the test level			

Table 202, in accordance with DIN EN 60601-1-2, 6.8.3.201

22. ***Annexes and technical documentation***

22.1 ***Handling of sealed storage batteries***

When charging sealed storage batteries by water electrolysis at the positive electrode, the oxygen released is guided through a glass mat from the positive to the negative electrode and converted back to water again after a series of chemical reactions. During charging, part of the oxygen also enters the shared gas compartment. The housing of sealed storage batteries is designed to act as a pressure vessel through which reinforced walls prevent the excess oxygen from escaping until complete recombination at the negative electrode occurs. If improper charging is carried out, hydrogen along with oxygen also arises at the negative electrode. This hydrogen cannot be converted to water, but rather discharges including the oxygen present in the gas compartment via the safety valves after the permitted excess pressure level has been exceeded. If improper charging is avoided, no water loss will occur in sealed storage batteries and the storage batteries are completely maintenance-free. During storage and energy extraction there is no oxygen in the gas compartment and the storage battery has low pressure. Opening the valves must be avoided in all cases as if oxygen enters them, the negative electrode will be oxidised. This will result in irreparable damage and could lead to the complete power failure of the storage battery.

22.2 *Maintenance plan & maintenance recommendations*

When	What	Note
Before driving	General Check for proper function	Carry out check yourself or with an assistant
	Check magnetic brake	Carry out check yourself or with an assistant If the power wheelchair can be pushed, have the brake repaired immediately by a specialist workshop. - Danger of accident!
Before driving in the dark	the lighting unit Check that the lighting system & reflectors are working properly	Carry out check yourself or with an assistant
Check, if driving behaviour is suspicious	Have the tyre pressure checked.	Visit a specialist workshop. (Sanitary shop/contact PARAVAN)
	Adjustment screws & Bolt connections Check screws or nuts for tight fit.	Carry out check yourself or with an assistant Tighten loosened screws. Visit a specialist workshop.

When	What	Note
Every 6- 8 months	Wheel fastenings Check wheel nuts or bolts for tightness	Carry out check yourself or with an assistant Tighten loosened wheel nuts or bolts firmly and retighten after 10 operating hours or 50 km If necessary, visit a specialist workshop.
Every 2 months	Check tyre tread Minimum tread depth = 1 mm	Carry out visual inspection yourself or with an assistant. If the tyre tread is worn or damaged, consult a specialist workshop for repair..
Every 6 months	Check: - Cleanliness - General condition	See chapter 18.2 Cleaning & maintenance Carry out yourself or with an assistant.
Every 12 months	Inspection work - Wheelchair - Charger	To be carried out by the specialist workshop

22.3 *Customer service book*

General

- 1. Inspection (12 months after commissioning)
Date: _____ Signature: _____

Stamp: _____

Information

- 2. Inspection (annual)
Date: _____ Signature: _____

Stamp: _____

Prepare

Operate

- 3. Inspection (annual)
Date: _____ Signature: _____

Stamp: _____

Help

- 4. Inspection (annual)
Date: _____ Signature: _____

Stamp: _____

Technology

> 5. Inspection (annual)

Date:

Signature:

Stamp:

> 6. Inspection (annual)

Date:

Signature:

Stamp:

> 7. Inspection (annual)

Date:

Signature:

Stamp:

> 8. Inspection (annual)

Date:

Signature:

Stamp:

General

Information

Prepare

Operate

Help

Technology

22.4 EC declaration of conformity

Declaration of Conformity

Version 1

PARAVAN GmbH
Paravanstraße 5-10
72539 Pfronstetten-Aichelau
GERMANY

We declare under our sole responsibility that the product listed below

Wir erklären in alleiniger Verantwortung, dass das unten aufgeführte Produkt.
Nous déclarons sans notre propre responsabilité que le dispositif médical

Product description; Code, Type, Model, Intended purpose

Produktbezeichnung; Code, Typ, Modell, Anwendungszweck

Description du produit; code, type, modèle, destination,

Power Wheelchair, designed for the mobility of a person with disability indoors and outdoors. Elektrollstuhl, konzipiert für die Mobilität einer Person mit Behinderung im Innen- und Außenbereich.

Fauteuil roulant électrique conçu pour la mobilité d'une personne handicapée à l'intérieur et à l'extérieur.

PR35S

G052108380

manufactured by:
hergestellt durch:
fabrique par:

PARAVAN GmbH
Paravanstraße 5-10
72539 Pfronstetten Aichelau
GERMANY

Single registration number (SRN)

DE-MF-000006423

meets all the provisions of the Regulation (EU) 2017 /745 on medical devices, especially Annex I - III, which apply to it.

allen Anforderungen der Verordnung (EU) 2017/745 über Medizinprodukte, insbesondere Anhang III, entspricht, die anwendbar sind
remplit toutes les exigences du Règlement (UE) 2017/745 relatif aux dispositifs médicaux, en particulier annexe III, qu'il concerne.

Device Classification according to Annex VIII

Produktklassifizierung nach Anhang VIII
Classification selon l'annexe VIII

Class I

Klasse I
Classe I

Initial date of first Declaration of Conformity:

Erstmalige Ausstellung der Konformitätserklärung:
Année de première Déclaration de Conformité.

05/2021

Valid until:

Gültig bis:
valable jusqu'à:

31.12.2025

Place and issue date:

Aichelau, 20.05.2021

Ausstellungsort und -datum:

Lieu et date de délivrance:

Operations Manager

Roland Arnold

Geschäftsführer
Le Directeur des Opérations

Geschäftsführer: Roland Arnold
Aichelau, St. Gallen, Schweiz
Umsatzsteuer-ID: DE237925479
IK: 590841201
Kreissparkasse Reutlingen - IBAN: DE56 6405 0000 0100 0049 00 - BIC: SOLA DE33 DEU
Sparkasse Reutlingen - IBAN: DE29 6409 3000 0049 7200 00 - BIC: SCKN DE33 MUN
Commerzbank AG Reutlingen - IBAN: DE27 6403 0033 0428 8270 00 - BIC: COBA DEFF 440

1

Fig. 103: EC declaration of conformity

22.5 *Log of instructions provided upon delivery*

Due to the flexible setting options of the PR 35S, the following information should be noted:

When using the tilt function:

- > It must be ensured that the seat is not tilted too far forwards or backwards, as otherwise you could slip out of the seat.
- > The tilt function is set to your weight.
- > Tilt the wheelchair first, then set the backrest.
- > Always wear the seatbelt when using the tilt function.
- > When using the tilt function, only half the speed of the selected movement level is possible.

Seat / backrest in the special orthopaedic seat

- > The backrest must only be adjusted as far as is necessary, as the motor is not powerful enough to lift the weight of the driver. Use the tilt function first.
- > When adjusting the backrest and the tilting angle, be aware of attachments (backpack, etc.).

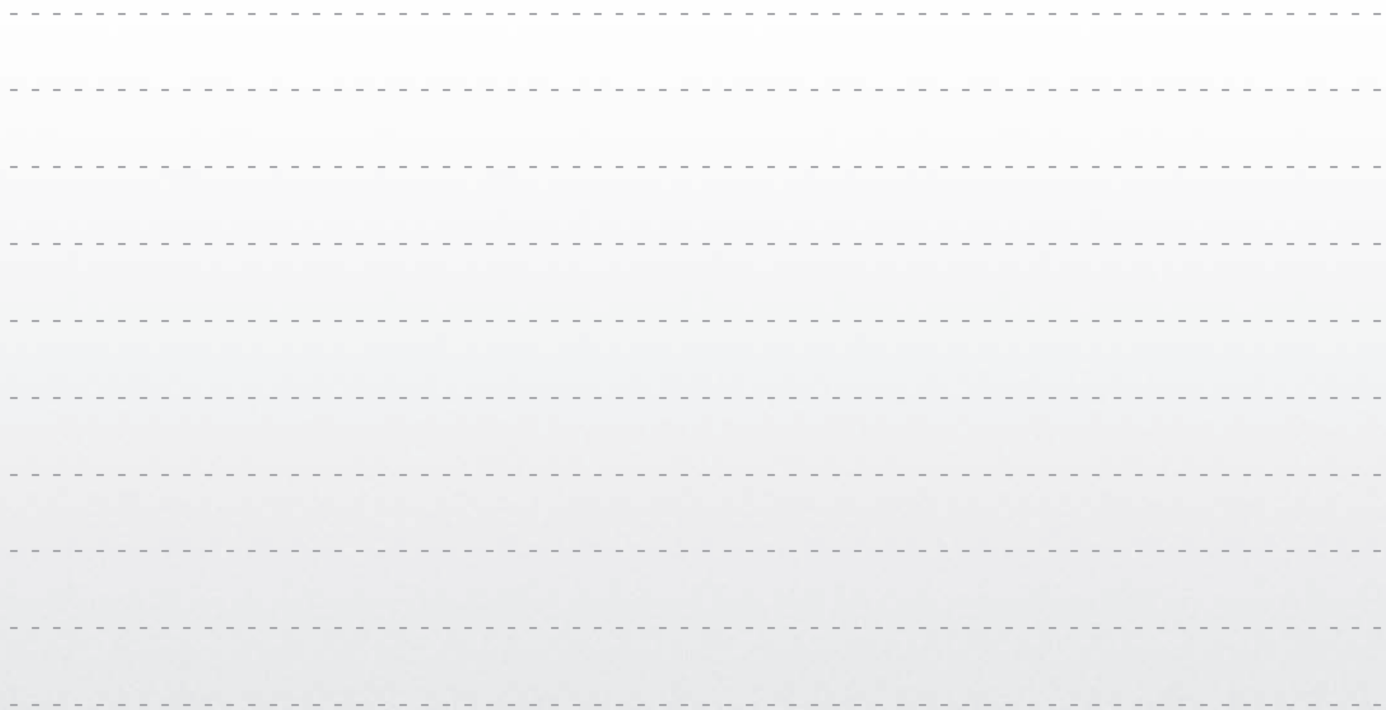

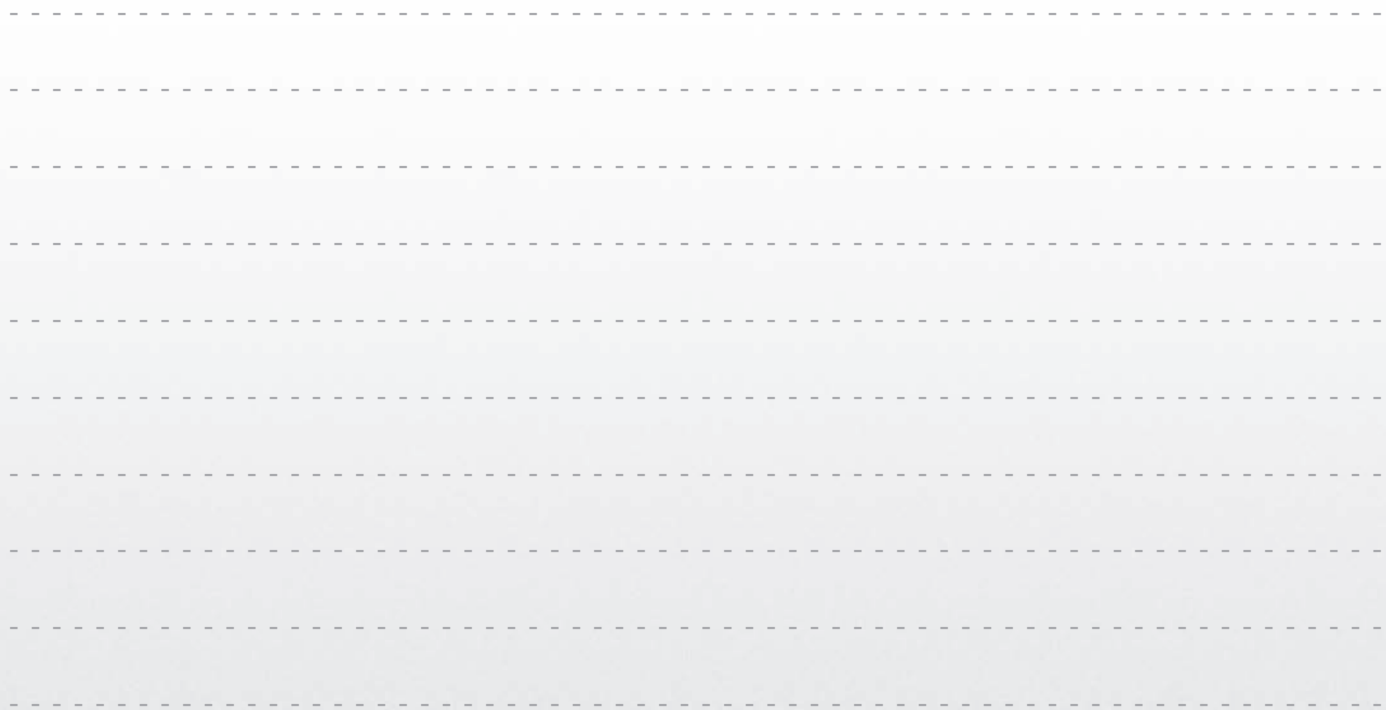



PARAVAN WHEELCHAIR SERIES

User manual
PR 35 S

ORIGINAL INSTRUCTION MANUAL



Paravan GmbH

Paravanstraße 5-10
72539 Pfronstetten-Aichelau
Germany

Phone: +49 (0) 73 88 / 99 95-60
Fax: +49 (0) 73 88 / 99 95-999
Email: info@paravan.de

www.paravan.com